



Solar Powered Sewing Machine Evaluation Report

SELCO Foundation



Executive Summary

Selco foundation designs and implements various energy efficient livelihood programmes for the underprivileged and vulnerable communities in urban, rural and tribal settings. Solar powered sewing machine was one of its pioneer livelihood projects. This project aims to support individuals who are engaged in / willing to start tailoring activities as an income generation activity. Customized solar powered solutions are provided to enrolled entrepreneurs, which help them increase their productivity and increase their income. This project was initiated in 2015, and so far has covered more than 200 entrepreneurs from diverse geographic and community settings.

Selco foundation conducts periodic monitoring and evaluation activities, which help us to learn from the field on the implementation of our programmes and to strengthen them further.

Such evaluation and impact assessment provides us the opportunity to critically reflect on the programmes and processes and to see how we could implement them in a better manner. This document captures the details of solar powered sewing machines, one of our pioneer livelihood projects.

The reader would get an idea about our livelihood projects approach, major principles and considerations, and finally the social impact of this project.

This M&E exercise was conducted by an external consultant and this document is primarily meant for Selco foundation members, partner organisations, and funders.

About SELCO Foundation

Set up in Oct 2010, SELCO Foundation engages in field-based research and development and ecosystem building for the deployment of clean energy solutions that alleviate poverty amongst tribal, rural and urban poor communities. The organization works closely with energy entrepreneurs and partners from various developmental sectors to broadly address three mandates:

- Identifying and bridging gaps in the ecosystem needed to deploy energy solutions
- Building holistic, replicable solutions that combine Technical, Financial and Social (community dissemination) aspects
- Identifying and catering to the needs of the heterogeneity within the poor

Through a network of research and innovation labs and focus areas, SELCO Foundation is attempting to become a hub where solutions are developed based on field conditions and also where all parts of the ecosystem can be addressed while designing and implementing a solution. These are then replicated in similar contexts, within India and other parts of the developing world, through social enterprises and partners in the development sector or institutions.

Livelihood Initiatives at SELCO Foundation

Poor access to reliable, affordable and clean energy is one of the key challenges faced by most rural livelihood sectors in India. As per the UNDP estimates, more than 40% of the population does not have a reliable supply of energy, and many rural livelihood enterprises need to depend on other alternate sources such as diesel generators, which are difficult to maintain and are expensive.

SELCO foundation aims to bridge this gap, by providing sustainable and clean energy solutions to different livelihood initiatives. It provides support to small and medium scale entrepreneurs with energy efficient solar solutions to improve productivity and thus increase income. It works with different entrepreneur categories, from secure livelihoods to insecure livelihoods that are marginal and/or seasonal. Also appropriate financial and market linkages are provided to the customers. Apart from this, Foundation also collaborates with other organisations for entrepreneur training, product value-add and diversification, in addition to the technology itself.

Social impact assessment for livelihood projects– Selco

APPROACH

Social impact assessment can be understood as a “processes of analysing, monitoring and managing the intended and unintended social consequences, both positive and negative, of planned interventions (policies, programs, plans, projects) and any social change processes invoked by those interventions”. Social impact assessment covers the environmental, socioeconomic and scientific factors, which are often left out of the traditional mechanisms of monitoring and evaluation (Moñux et al., 2006). Social impact assessments aim at enhancing the benefits of projects to impacted communities and to identify and mitigate the negative impacts. It also stresses on revising projects and ancillary activities to ensure greater benefits to communities.

Social impact assessment variables point to measurable change in human population, communities, and social relationships resulting from development project or a policy change. Social impacts assessments could be conducted for large scale projects having national relevance to a small scale specific focussed intervention, such as a reservoir and highway development or natural resource development to the assessment of a specific livelihood intervention. Here, we are looking at the impact of a small livelihood project- solar-powered sewing machines.

SUSTAINABILITY

Sustainability is a key term associated with impact assessment. Selco Foundation seeks to inspire and implement socially, financially and environmentally inclusive and sustainable livelihood solutions for the poor and vulnerable sections of the population. A livelihood is considered to be sustainable when it can cope with and recover from stresses and shocks, maintain or enhance its capabilities and assets, while not undermining the natural resource base. The key elements of sustainability are:

1. Creation of working days – This relates to the ability of a particular combination of livelihood strategies to create gainful employment for a certain portion of the year.
2. Poverty reduction – The poverty level is a key criterion in the assessment of livelihoods. Various measures can be used to assess the level of poverty, based on income or consumption levels.
3. Improved well-being and capabilities is another parameter to say if a livelihood intervention is sustainable or not.
4. Livelihood adaptation, vulnerability and resilience – The ability of a livelihood to be able to cope with and recover from stresses and shocks is central to the definition of sustainable livelihoods. Those who are unable to cope (temporary adjustments in the face of change) or adapt (longer term shifts in livelihood strategies) are inevitably vulnerable and unlikely to achieve sustainable livelihoods.

The main types of social impacts that occur as a result of any of the livelihood interventions can be grouped into the following overlapping categories (figure 1)

Lifestyle/Social Impacts

Changes in the way people behave and relate to family and friends in their day today life

Financial Impacts

Savings, household assets, financial inclusion

Community Impacts

On infrastructure, services, voluntary organisations, activity networks and cohesion

Quality of Life Impacts

On sense of place, aesthetics and heritage, perception of belonging, security and liveability, and aspirations for the future

Health Impacts

On mental, physical and social well being

Rationale

Tailoring is one of the most important livelihoods in India. Traditional tailors who generally serve local customers in small cities and villages use manual sewing machines. To achieve higher productivity some of them modify their machine by retrofitting motor with it. Mostly a universal motor of 1/10HP or 1/12HP is used for this purpose.

It was noticed that, when a 1/12HP universal motor consumed around 100 Watt to run a tailoring machine at nearly 1000 spm (stitches per minute) speed, the same results could be achieved by a 60W PMDC motor consuming only 75 Watts. By introducing more efficient PMDC motor the energy consumption had brought down by 40%. This reduces the capital cost about 15%. The table below gives the technical and financial details of the model.

There is another segment in tailoring industry which practices tailoring on a large scale.

Bigger size heavy-duty industrial sewing machines are commonly used for such purpose.

This type of machine has a clutch attached to the motor. When the pedal is pressed the clutch gets engaged and the machine starts stitching. After the pedal is released the clutch gets detached but the motor still rotates at no load, consuming at around 100W. This clutch motor was replaced by a Variable Frequency Drive (VFD) controlled 1/3HP induction motor. The VFD eliminates the ideal running of the motor and saves more than 50% of the energy consumption. It also significantly reduces the cost of system (more than 40%). Additional benefit was that it suppresses the high starting current of motor. It helps to avoid the need of an oversized inverter just to withstand the high starting current. At the same time the inversion efficiency get increased due to improved percentage loading.

	Universal Motor		PMDC Motor	
Material	Capacity	Unit	Capacity	Unit
Solar Panel	50 Wp, 12V	2	60Wp, 12V	1
Solar Battery	60Ah	1	40Ah	1
Charge Regulator	10A, 12V	1	10A, 12V	1
DC Boost Charger	150W, 12V/220V	1	NA	
Motor with Accessories	60W	1	60W, 12V	1
Cost	Rs. 19,700	Rs.16,000		

Types of Sewing Machines

STRAIGHT STITCH SEWING MACHINE

There are different types of straight stitch sewing machines. The pedal operated machine is an entirely manual one without a motor and churns out 300 stitches per minute. This type of machine is mainly used to stitch shirts, blouses and school uniforms. These machines can be retrofitted with a dc motor and solar power the whole setup. The productivity doubles when the machine is shifted to a solar powered system from a manual pedal operated one, for the same hours of operation.

FASHION STITCH SEWING MACHINE

There are different types of straight stitch sewing machines. The pedal operated machine is an entirely manual one without a motor and churns out 300 stitches per minute. This type of machine is mainly used to stitch shirts, blouses and school uniforms. These machines can be retrofitted with a dc motor and solar power the whole setup. The productivity doubles when the machine is shifted to a solar powered system from a manual pedal operated one, for the same hours of operation.

INDUSTRIAL BASED SEWING MACHINE

These sewing machines are used to stitch in industrial production spaces and are a little bigger in size than the straight stitch machines and also have a sturdier base. These machines have a speed of 2000-2500 stitches per minute and also have various needle variations. This allows the stitching of jeans and bags and these machines are installed only in regions which need hard needles for stitching and stitching needs to be done fast as well. These machines use a clutch motor of 0.33HP. These motors keep running all the time whether stitching is being done or not. Close to 100W is wasted all the time because of this inefficiency in design. These clutch motors were replaced by a VFD controlled induction motor to reduce the cost of solar powering the setup. Our initial observations show that there is about a 50% savings in energy per day. All the systems are designed for 8-hour shift during daytime (typically 9am to 5pm).



Evaluation Methodology

As a preparatory exercise, all the relevant materials and documents about the project were reviewed. Subsequently, the evaluator visited the project sites and had detailed interactions with the Selco field staff, who were involved in the implementation of the projects. For the purpose of social impact assessment, the entrepreneurs were contacted and had detailed interactions with them and their family members. In order to understand the process of the intervention and its impact, the following methodology was used:

- Discussion with Selco staff who were involved in the project conceptualization and implementation
- Visits to randomly selected field sites; semi-structured interviews with the entrepreneurs
- Review of existing documents and other relevant implementation data bases
- Analysis of the data collected, sharing the preliminary findings with Key staff members at Selco, incorporated their feedback and suggestions

Both positive and negative, intended and unintended impact were considered while looking at how the solar powered sewing machines have had an impact in their lives (a detailed tool is provided as annex-1)

Mainly three types of entrepreneurs were identified:

- Individual entrepreneurs, where they worked alone and undertook tailoring orders. Most of the individual entrepreneurs were either doing tailoring work from home, or had their shops attached to their houses. Only a handful of entrepreneurs had set up tailoring shops away from their houses.
- A small-scale business model, where an organisation installed a few solar powered sewing machines and employed a few people, who were paid for their tailoring work (details below).
- A solar unit was used to provide training in tailoring. Specific example for such a model is from Kasargod district of Kerala (details below). Five sewing machines have been purchased by a trust working in the area. These sewing machines are kept in a school, and women from the area are trained in tailoring.



Social Impact

The following section highlights the social impact of solar powered sewing machine project. The site visits and detailed interactions with entrepreneurs helped understand how these solutions have impacted their livelihoods. All the entrepreneurs visited were using the solar powered systems and found positive changes with regard to their working pattern and productivity. The table below lists out a few changes mentioned by the entrepreneurs as a result of switching to a solar powered solution.

Impacts as reported by entrepreneurs

Increased savings	Ability to purchase household assets	Able to pay for children's education
Better time management, ability to complete work orders on time	Improved health and well being, less body aches, reduced drudgery	Ability to have leisure time activities
Enrolment in insurance or other welfare programmes	Improved participation in social gatherings	Started renovation of the house



Case Study – Porgai: Sittilingi tailoring centre

Tribal Health Initiative (THI) is an organization, based in Sittilingi valley of Tamil Nadu, working for the tribal communities in the area, through a variety of programmes in health care, community health, farming and craft work. Porgai, a tribal craft initiative, undertaken by THI, aims to create a livelihood option by reviving the traditional craft of Lambadi, one of the tribes in Sittilingi. Porgai means 'pride' in the Lambadi dialect.

Women groups from the area have revived this traditional craft, and are engaged in tailoring and craft as a livelihood option. THI has set up a tailoring centre for the women for Lambadi group, where they make a variety of garments and accessories, for both men and women. They do the traditional embroidery on kurtis, skirts, wraparounds, sarees etc. They also make cushion covers, tablemats & runners, framed showpieces, purses/wallets, mobile pouches and bags. These products are marketed with the help of THI.



Power failures were very common in the Sittilingi valley area, due to which the women were finding it difficult to complete their orders in a timely manner- thus, access to energy was identified as a key factor in hampering further livelihood advancement for the women in the centre. Seven solar powered sewing machines were installed in the centre.

Seven to eight women work in the centre, which are from the nearby villages. They are paid as per the work they complete, on a pay per piece basis. The women reported that solar powering the machines has helped them to complete more work and they are able to earn more. The completed products are sold through exhibitions and Porgai's online store.

Increase in income

All ten entrepreneurs reported that there is a substantial increase in their daily earnings, since the solar system has been installed. This money is often used to clear off financial liabilities they had incurred previously, to improve living conditions by purchasing household items or renovating the house. Most of the entrepreneurs view children's education as a priority and reported that they would like their children to complete their studies, and use the extra earning to support their education. Some of them have started investing small amounts of money in chit funds or other recurring deposit schemes run by their own community members. Depositing money in formal financial institutions is not very common.

Case Study – Sujatha, Chitradurga, Karnataka

Sujatha is a 32-year-old married female entrepreneur, engaged in tailoring work for the last twelve years. Her husband is engaged in wholesale trading of different agricultural products. Her husband is the primary earning member of the family and her earnings supplement his income. She stitches Sari blouses, salwars and children's clothes. She does tailoring in her house and has a fixed customer base. There are other tailors in the area, but she reported she has got sufficient number of customers. The work is more during wedding season and festivals, but she has got orders to keep her busy throughout the year. Her working hours are flexible, as she also needs to attend to her household chores. She also sells Saris in a small scale, and that has helped her to get more tailoring orders; usually people who buy saris from her would get the blouse stitched from her.

She was using a motorised sewing machine, but switched to a solar machine as there were frequent power cuts and she wasn't able to deliver the clothes on time. Also due to continuous stitching, she used to suffer from frequent leg pain, which prevented her from working continuously. She reported that after solar installation, she is able to keep the delivery date promised to the customers, which in turn has increased her work due to dependability. After installing the system, she is able to earn about Rs. 800 to Rs. 1000 per day. She is happy about her decision to solarise the system, she also reported that there is timely maintenance support from Selco team.



“I don't have any issues with this machine. This is my Lakshmi, without this my life would have been in trouble”- Woman entrepreneur, Chitradurgadist, Karnataka

Case Study – Nagarathana, Karnataka

Nagarathna is a 30 years old married female entrepreneur from Chitadurga district of Karnataka; she is engaged in tailoring work for the last ten years. She was using a manual pedal operated machine till Selco foundation provided her with a solar solution. She usually works for 5 hours a day, but during peak season, she works about 10 hour per day. She is the primary earning member. Her husband works as a driver, but since he is an alcoholic, she has to take care of household expenses and children's education. The solar solution was installed with the financial assistance from SKDRDP, once the solar system was installed, she is able to earn more and with that she has already cleared the loan and was able to also clear the soft loans taken before. She used to earn 10,000 to 12,000 before and now earns about 15000- 20000 per month, once she switched to the solar machine.

She stitches Salwars and sari blouses and is able to complete 6-8 blouses per day. She also stitches school uniforms for girls. She is able to take care of household expenses and children's school fees. With the remaining savings, she has started some recurring deposits. She is able to save about 5000 rupees per month through these deposits. Apart from that, she also runs a small money lending business; she gives credit to her neighbours and charges interest for that.

There are many tailors in the area, but she has fixed customers. She is very happy with the existing client load, and wants to continue like this, no plans of business expansion. She lives in a rented house and is planning to construct a new house. Overall, the entrepreneur is very happy with the solar solution and reported that it has actually changed her life in a positive manner.

Improved Working Conditions as an Output

Many of the entrepreneurs have their tailoring shops attached to their houses; most of them were also provided a light along with the machine. This eases their work, especially during evening hours. This also allows them to have flexible work timings and so reduces their drudgery. Installation of solar powered sewing machines has reportedly helped most of the entrepreneurs to complete their work orders on time, and so to take up more work. Most of the entrepreneurs reported that their productivity increased between 30-40% and a few reported doubling their productivity. In case of women, they are now able to manage household chores along with tailoring, which they found difficult while working on manually operated or electrified machines.



Case Study – Ramsingh Kabadi, Kalahandi, Odisha

Ramsingh Kabadi is a 35-year-old male entrepreneur from Badchatrang village in Kalahandi District of Odisha. He used a manual sewing machine and was unable to keep up with his orders, especially during the wedding and festival seasons. Even though Ramsingh had electricity at home, he did not want to shift to a motorized sewing machine because of the erratic and poor supply of the grid and instead, want to get a solar system installed.

Ramsingh needed financial assistance to get the system installed and it was challenging for him as he did not have a bank account. The team facilitated a loan for him from MUDRA (Micro Units Development and Refinance Agency) bank loan from Syndicate Bank, a financial product focussed on financing small businesses. He recollected that approaching the bank for getting assistance and completing the formalities itself was overwhelming for him and it almost took about five months to complete the whole process.

Today, Ramsingh is able to meet the seasonal demands and keep up with the orders, resulting in higher income. Increasing his productivity by 1.5 times per hour, Ramsingh has seen an immediate increase of INR 2500 per month. His earnings are expected to go higher during the festival season. Further, a solar light in his shop allows him to work through later in the evenings as well thus, allowing him the flexibility to take large number of orders. Six months after the intervention, Ramsingh has been paying his monthly instalments on a regular basis. Recently, he has also approached the bank for a second loan to construct and expand his current tailoring shop, buy another machine so his brother can join him in his tailoring shop. Apart from the financial gains, the whole experience of installing the solar system helped Ramsingh to be more confident and outgoing, with his interactions with formal financial institutions.



Case Study – Savita, Udupi, Karnataka

Savitha is a 28-year-old married woman entrepreneur from Haladi village, in Kundapura taluka, Udupi district. She lives in a joint family, along with her husband and child. Her husband works as a driver. She is engaged in tailoring for the last three years. She set up this tailoring shop in 2016. She undertakes ladies tailoring services; she stitches Saree blouses, Salwar, and school uniforms for girls. She works from 9 am to 6 pm, six days a week. The work load is more during festivals and wedding season.

The area has about ten tailoring centres, so there is competition between entrepreneurs. Also, hers being set up recently, it may take some time to be stable in the business.

Frequent power cut was affecting her work and she was unable to complete the work on time. A need assessment was conducted to understand the entrepreneur's current earnings and viability of installing a solar powered sewing machine. After having detailed interactions with her, a solar powered system was installed in May 2017.

She is able to take up more work after solar powering the system. Earlier, she was able to stitch 2 blouses and now she can complete 4 blouses in the same time. She is able to deliver orders on time, which has helped her establish a good relationship with customers who keep returning to her for sewing services. Earlier she used to earn about 200- 250 rupees per day, after installing the solar machine, on an average she is able to earn 400- 500 rupees a day. Similar to other entrepreneurs, there are seasonal variations in her earning, i.e. during wedding season it can go up Rs. 600-750 a day and during off seasons, it could be as low as Rs. 300 per day.



She also trains interested candidates and keeps them to assist her in her work, but during the time of assessment, there were no trainees under her. She reported that she doesn't earn much from the training, as the number of candidates is very few in number.

Improved Social Participation

Many of the entrepreneurs reported that they are able to manage their time more efficiently, and they get enough free time to be engaged in other social activities. A few reported that they are able to attend family gatherings and local festivals, as they do not have to adjust their work time depending on electricity supply. We did not see any instances of any change in political participation.

Case Study – Suma, Udupi, Karnataka

Suma is a 25-year-old unmarried woman entrepreneur, engaged in tailoring work for the last four years. She has studied up to PUC, and was working in a printing press before she started doing tailoring work. Her house did not have grid electricity connection.

Her mother is a self-help group member run by SKDRDP, and through them they approached Selco team and explored the possibility of installing solar lights for the house. Once the team did the needs assessment, she got 2 solar lights and a fan installed, along with the sewing machine. She was financially supported by SKDRDP, which she has already paid off. She is able to save about 5000- 6000 per month.

She reported that once the installation was done, she was able to stitch four sari blouses a day, where she was able to do only 2 blouses earlier. She is able to stitch in the night, as there is light now. She also reported that she doesn't feel the work pressure and she is able to take periodic breaks– thus giving her flexibility in work timings. Due to less work pressure, she is able to visit her relatives and also attend festivals. With her savings, she purchased another sewing machine, later she plans to have that solar powered as well. Initially the system had some issues with the pedal, but now it is resolved and is working fine. She is very happy with the installation and on her own initiative she got a TV that works on solar power.



Improved Health & Wellbeing

Most of the entrepreneurs reported that machines for longer periods was causing various health issues, such as body aches and pains, and now after switching to solar powered machines, that has substantially reduced. One of the entrepreneurs is physically disabled and for him specifically, the solar system has helped in reducing the drudgery and other health issues. From the entrepreneurs' words, erratic power supply was also a cause of anxiety and stress. Now the flexibility of work timings gives them opportunity for other leisure time activities, and feelings of improved wellbeing.

Case Study – Venkatesh, Kolar, Karnataka

Venkatesh is a 39 years old married male entrepreneur, engaged in tailoring for the last 19 years. He has a physical disability due to Polio Mellitus. He is educated up to 2nd PUC. He got married in 2008; his wife has studied up to 7th standard. He is the primary earning member of the family.

During a demonstration of home lighting systems for his village by the Kolar branch of SELCO Solar, Venkatesh enquired about the scope of solar powering his sewing machine. The branch with help of SELCO Solar carried out an assessment of system requirements and designed the system for an optimized capacity. He was using a AC motor sewing machine, but due to frequent power cuts, it was not being very useful.

The scope for potential savings on electricity bill and opportunity for Venkatesh to meet the surplus demand of his consumers were the main drivers for taking up the project..

Another key reason was that the health issues he faced due to operating the manual sewing machine. The SELCO Solar team carried out multiple visits to the site and interacted with Venkatesh to figure out the problems he faced with his existing sewing machine setup and also the technical specifications of the same. The need assessment also covered the necessary financing requirements that were facilitated by SELCO Solar with the support from Pragati Krishna Grameen Bank. After a thorough assessment, SELCO Solar replaced the inefficient and oversized AC motor with a more energy efficient DC motor (60 W) and solar powered the system. Solar panels of 60 Wp with 30 Ah battery were used to provide 8 hours of backup/day. The system was designed to run for 8 hours a day and Venkatesh confirmed that he is able to use it for the same.

After switching to solar, he is able to stitch double the volume. He used to stitch 3 blouses, now he is able to stitch six blouses. Before the machine was solarized, he used to complete the school uniform orders in a month, now he is able to finish it in fifteen days. He said during May and June, he was not able to take up any other work, but now he can do school uniforms along with other orders.



He is one of the older entrepreneurs associated with Selco, and in the last two years his income has doubled. He was able to purchase many household assets; he got a gas connection, a diwan cot, and a showcase with the money earned after solarisation. He has undertaken house repair work of his house with financial assistance from GramaPanchayat, a total of 80000. Remaining money he has taken soft loan, a total of Rs. 60,000/- paid of 30,000/-

He recollected that, working with a manually operated pedal caused a few health issues for him. He used experience frequent leg pain, which affected his work and the productivity and that was the main reason for him to switching to solar powered machine. Once he installed the solar sewing machine, he feels much better. He doesn't have the pain as he takes periodic breaks in between.

Case Study – Nagarajappa, Chitradurga, Karnataka

Nagarajappa is a 42-year married entrepreneur from Chitradurga, Karnataka. He has been engaged in tailoring work for more than 20 years. He lives along with his wife and children and his wife also assists him in tailoring. As their house is small and did not have enough ventilation, it used be dark and they had to use the lights even during the daytime. The family has an electricity connection through Bhagya Jyothi scheme, which provides free power supply up to 40 units. But their electricity usage would often go beyond 40 units, for which they had to pay huge sums as electricity bill. Another issue that affected his work was the frequent power cuts in the area.

They came to know about Selco's solar innovations, through the SKDRDP they approached the Selco solar staff and got the solution installed with the financial support from SKDRD.

According to him, the solution has helped him to reduce his daily working time by three hours and he is able to get enough rest. Earlier he used to suffer from aches and pains, which has considerably reduced after the solar installation. Before the solar installation, he used to earn about Rs. 7000/- per month and after he switched to solar solution it increased to 9000/- during non-peak seasons and during peak season, he is able to ear Rs. 12,000/-His daughter has taken up part time degree course and wants to complete that. Overall, he is happy with his earnings as well as the after sale support from Selco.



Challenges & Learnings

Different contextual, household as well as individual factors affect the outcome of any livelihood projects. While factors such as market linkage, supply chain issues and financial linkages affect the entrepreneurs at large level, specific individual contextual factors such as family support, other vulnerabilities such as age, gender and disability too can have a bearing on their earning capabilities. There is also a wide variance in the way entrepreneurs perceive their own work and earning potential and that too affect the outcome positively or negatively. A few key such learnings and observations are given below:-

- Financial linkages crucial, in the rural areas, where people do not have any bank accounts, it is difficult to arrange for financial assistance. Also, the banking structures present at the grassroots may not be comfortable towards financing such business models. Hence, it takes time to build banker's confidence and proving the business viability.
- Market linkages were found to be optimal among the entrepreneurs visited, most of them were content about their business and earning capabilities.
- Selco Foundation could play a key role in linking the entrepreneurs to the training opportunities, which would in turn help in boosting their business, especially for young and upcoming entrepreneurs.

- Role of partner organization is important, constant feedback from partner organisations help in rendering timely after sale services. Since it is a livelihood project, prompt after sale service is crucial.
- There is difficulty in procuring motors locally and there is a need to support local vendors to strengthen the supply chain; currently the partner organisations depend on the solar enterprises to arrange the motors.



Way Forward

It is evident that the solar powered sewing machines are a sustainable livelihood option for the poor and vulnerable, irrespective of the settings. However, there are certain factors that need to be looked into, if the solution has to be scaled up. The key recommendations based on the M&E are given below:

- Most of the entrepreneurs in Karnataka are financially supported by SKDRDP. It is imperative to identify more partners for financial linkages.
- Self-employment schemes and subsidies provided by different state governments should be explored for financial assistance, such as Udyogini scheme of Karnataka. Similarly different other potential schemes should be explored; for example, there are many schemes specifically targeting women or SC/ST communities. Such avenues could be explored.

- For existing customers, information about skill building and business expansion could be shared. For example, there are many NGOs (eg. AWAKE, Bangalore) focusing on women entrepreneurs, providing them training in tailoring etc. For customers who wish to learn embroidery or wants to expand business, could be assisted.
- The needs assessment has to take into account other confounding factors such as personal entrepreneurial drive, design sense, customer service, which may affect the productivity or income levels. Another crucial aspect to be considered is family support, which may also be a predictor of the impact.



ANNEX I

TOOL USED FOR EVALUATION AND IMPACT ASSESSMENT

Interview schedule for sewing machine entrepreneur

Personal details

- Name:
- Age:
- Education:
- Details of family in brief- (total number of members, No of children: School/ college going etc)
- No of adult earning members (collect details of their profession, who is the primary earning members, what is the average household income)
- Details of the house: Own/rented, what kind of house, household assets: agricultural land details, live stocks etc

Details of work

1. No of years in this work (when did she/he learn tailoring? Any specialization- example embroidery)
2. When did they install the solar sewing machine- collect the details of the process- who contacted, time taken to complete the installation
3. Financials – bank loan or self funded, total money spent- if taken loan then the EMI paid so far
4. Is she the primary earning member?
5. Any other income generating activities?
6. How is the after sale support from the selco team – any difficulty faces
7. The following section explores the impact of solar solution in entrepreneurs
8. Usual working hours – before and after installing the solar machine (check for any change)
9. Average earning – before and after (Individual income of the entrepreneur per month- if he/she is not able to say a monthly figure, ask for daily earnings- calculate it for the month and counter check with the entrepreneur. Get the details if the earning has increased how it is put to use- for example was she able to clear any soft loans, loans from bank, private institutions etc, details of interest paid, any household article purchased, any other- such children's fees, construction of own house or renovation of houses, financial linkages to banks – such as opening bank accounts, or any other micro finance institutions Future plans fro work- plans to expand – example, another machine, different type of stitching, giving training, sale of garments, giving training etc
10. Impact on health using this system compared to manual pedal/ electric (check for any specific health issues, and overall well being)
11. Any changes in household structure (for example children coming back – who were with relatives, any family member who had migrated has come back etc- we are looking for a positive change here) Improved access to social network
12. s (check for involvement is any of the formal /informal local governance or religious bodies, or any other associations)
13. Improved access to health services if any
14. Other general observations or feedback on entrepreneurs level of confidence, improved participation in household decision making (especially for women entrepreneurs)
15. Any other relevant information

ANNEX II

TECHNICAL SPECIFICATIONS OF SEWING MACHINES

Tech specs - Commercial sewing machine

Wattage	60W
Motor type	Permanent magnet DC motor
Rated voltage	12V DC
Rated current	6.5Amps
Rated efficiency	75%
Motor rated speed	3000rpm
Motor rated torque	2kg-cm
Typical machine speed	1000 stitches per minute
Machine stitch types	Straight stitch only
Speed control	PWM pedal control
Solar PV Module	60Watt-peak
Battery (Lead acid flooded)	40Ah @ C10, 12V
Charge controller	10Amps, 12V

Tech specs - Industrial garment machine

Wattage	230W
Motor type	(AC Induction motor 3Ph)
Motor input	Controlled by VFD
Speed control	VFD control

ANNEX II

TECHNICAL SPECIFICATIONS OF SEWING MACHINES

Tech specs - Usha Janome machine

Wattage	100W
Rated voltage input to VFD	230V, 50Hz single phase
Typical machine speed	1000 stitches per minute
Stitching pattern	Straight, zigzag and other embroidery patterns
Solar PV Module	150 Watt-peak
Battery (Lead acid flooded)	80Ah @ C10, 12V
Solar PCU with MPPT	800VA, 24V

ELECTRONIC CIRCUIT DIAGRAM

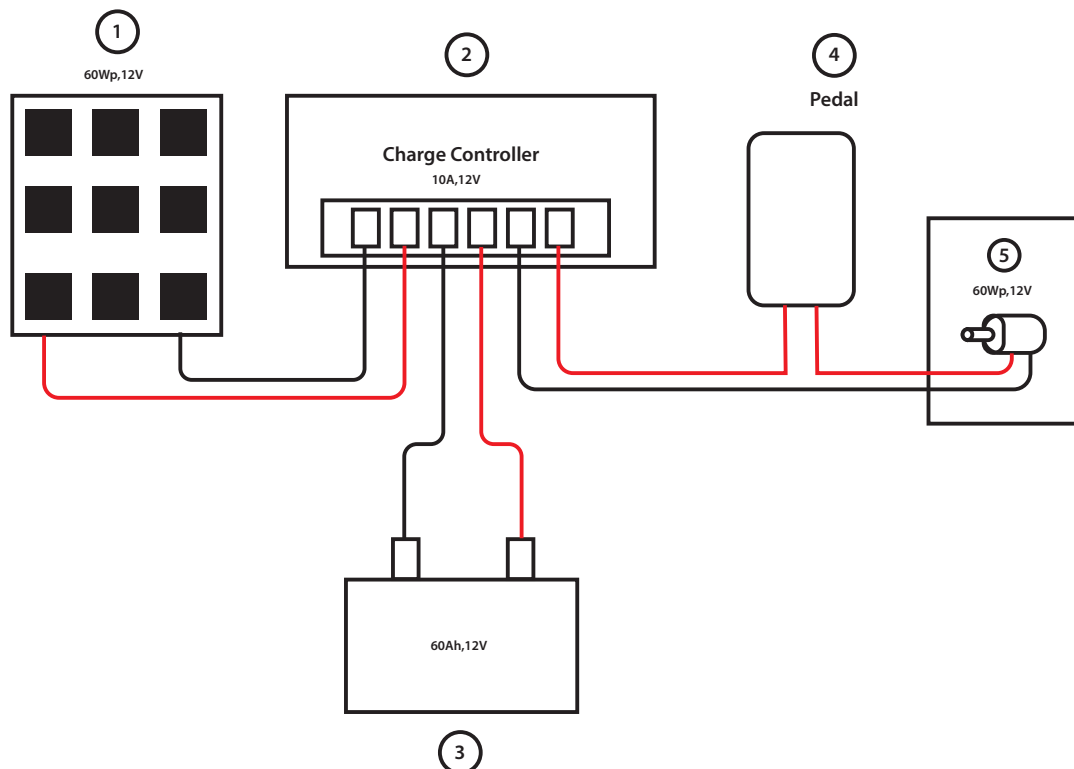

ANNEX III

SUPPLIERS

There are basically three suppliers for motors that we have looked at:

Rotomag: This is too big a company for us to source from currently. They have a motor of the specification that we want but are not the ideal partner to supply at the volumes that we want.

Dynaflux: This is a Belgaum based company that we are sourcing from currently but we are looking for a company in Bangalore to meet our requirements.

Agni Motors: They are a Bangalore based company and we are looking to source from in the future It will be easier to coordinate with them than coordinating with Dynaflux that is based out of Belgaum.

Note: We are looking for motor suppliers in Maharashtra and Gujarat also. We have tried to look for suppliers in other geographical regions as well but it is tough to find suppliers of dc motors due to the low demand. Delhi has a huge market for 2nd hand motors. Korean and Chinese manufacturers can be looked at but they are expensive.

Contacts of Vendors/Suppliers:

Dynaflux Motors:

MARCELO PADAKI

Factory Manager, MMC Electric Company Pvt. Ltd.

Plot No.154, SNO; 585, Machhe Industrial Estate, Machhe, Belgaum - 590014

Tel: +91 831 2411046 / 48.

Mobile +91-9341105264

Fax: +91 831 2411047

Email: admin@dynafluxindia.com Website: <http://www.dynafluxindia.com>

Emsys(Electronic parts supplier):

Mr.Gopi (Founder)

+91-9019370506

Emsys Electronics Pvt Ltd,

#36, 2nd Cross, Govardhan Gardens,

Dr H Anjaneyappa Industrial Estate,

Off Kanakapura Road, Yelchenahalli,

Bangalore - 560 062

info@emsyselectronics.com

Web - www.emsyselectronics.com

Sewng Machine and Spare Parts Supplier:

Sewing Sevice Centre

#26/1 Shop No 3, Jattappa complex,

Yelachenahalli, Kanakpura Main Road,

Bangalore 78 Ph: 9448577647

Warranty:

Straight Stich Machine

ANNEX IV

WARRANTY PERIODS

Straight Stitch

Sl. No.	Particulars	Warranty
1	Solar Module	5 years
2	Battery	5 years
3	Module Mounting Structures	5 years
4	Charge Controller	5 years
5	DC Motor and Accessories	1 Year
6	Cables, Battery Rack & Consumables	1 year

Industrial Stitch

Sl. No.	Particulars	Warranty
1	Solar Module	5 years
2	Battery	5 years
3	Module Mounting Structures	5 years
4	Inverter	1 year
5	AC Motor and Accessories	6 months
6	Cables, Battery Rack & Consumables	1 year
7	Drive	6 months

Usha Sewing Machine

Sl.	Particulars	Warranty
1	Solar Module	5 years
2	Battery	5 years
3	Module Mounting Structures	5 years
4	Inverter	1 year
5	AC Motor and Accessories	1 year (Service free but not replacement)
6	Cables, Battery Rack & Consumables	1 year
7	Core machine and internal parts	1 Year (Service free but not replacement)



SELCO Foundation

info@selcofoundation.org
www.selcofoundation.org

