



SELCO Foundation – Call for Vendors

The Supply, Installation and Commissioning & Comprehensive maintenance for 1 year of Solar Photovoltaic (SPV) Off-grid Systems.

SELCO Foundation – Procurement Officer

690, 15th Cross Rd, Jeewan Griha Colony, 2nd Phase,

J P Nagar, Bengaluru, 560078

procurement@selcofoundation.org

SELCO Foundation hereby invites bids for the Supply, Installation and Commissioning & Comprehensive maintenance of Solar Photovoltaic (SPV) off-grid systems for 1 year – for 1900 Anganwadi centres across the state of Karnataka during the year 2026-2027

The detailed tender document can be downloaded from

<https://selcofoundation.org/tender/>

As per the terms and conditions herein, all Bids should be submitted through the online form
(E-tender)



<https://forms.gle/WmbbLCgRBLMkoua89>

or submitted at the above-mentioned address

by 5 pm on or before 30TH June 2026.

Chief Executive Officer – SELCO Foundation



SELCO FOUNDATION

TENDER NOTIFICATION FOR

**SUPPLY, INSTALLATION AND COMMISSIONING & COMPREHENSIVE
MAINTENANCE**

OF

**SOLAR PHOTOVOLTAIC (SPV) OFF-GRID SYSTEMS FOR 1 YEAR –
FOR 1900 ANGANWADI CENTRES ACROSS THE STATE OF KARNATAKA**

TENDER DOCUMENT

Address for Communication

SELCO Foundation
#690, 15th Cross Rd, J P Nagar – 2nd Phase
Bangalore, Karnataka – 560078
Telephone: 080-26493145
E-mail: procurement@selcofoundation.org

DISCLAIMER

NIT (Notice Inviting Tender) No: 03/2026-2027

This tender by SELCO Foundation is for selection of vendors (hereinafter “**Organisation**” or “**Organization**”) for the work of Supply, Installation and Commissioning & Comprehensive maintenance of Solar Photovoltaic (SPV) off-grid systems for 1 year – for 1900 Anganwadi centres across the state of Karnataka during the year 2026-2027.

NOTE:

1. Though adequate care has been taken while preparing the Notice Inviting Tender (NIT) document, each Organization shall satisfy themselves that the document is complete in all respects. **Intimation of any discrepancy** shall be given to the Procurement Team at procurement@selcofoundation.org. If no intimation is received from any Organizations within seven (07) days from the date of notification of Request for solution (RfS)/ Issue of the RfS documents, it shall be considered that the document is complete in all respects and has been received by the Organizations.
2. **SELCO Foundation has the right to award the works under this tender to single or multiple Organizations and in multiple tranches based on the best technical specifications and lowest quote ascertained through this tender. Organizations can submit their quotes for a single cluster or overall projects as per feasibility.**
3. The implementation of Solar Solutions at the said Anganwadi Centres is subject to receiving the approval for installation from the local Anganwadi authorities.
4. SELCO Foundation reserves the right to cancel/ withdraw this invitation for bids without assigning any reason and shall bear no liability whatsoever consequent to such a decision.
5. SELCO Foundation reserves the right to modify, amend or supplement this document.
6. While this RfS has been prepared in good faith, neither SELCO Foundation nor their employees or advisors make any representation or warranty, express or implied, or accept any responsibility or liability, whatsoever, in respect of any statements or omissions herein, or the accuracy, completeness or reliability of the information, and shall incur no liability under any law, statute, rules or regulations as to the accuracy, reliability or completeness of this RfS, even if any loss or damage is caused by any act or omission on their part.

CONTENTS OF BID DOCUMENT

TENDER DOCUMENT	2
DISCLAIMER	3
NOTICE INVITATION TENDER.....	5
INSTRUCTION TO ORGANIZATION.....	6
ANNEXURE 1: TECHNICAL SPECIFICATIONS OF SOLUTIONS	18
ANGANWADI OPTION 1: DC SYSTEM	18
ANGANWADI OPTION 2: AC SYSTEM -WITH FULL WIRING	20
ANGANWADI OPTION 3: AC SYSTEM- WITH LOAD SEGREGATION.....	24
ANNEXURE 2- TECHNICAL SPECIFICATIONS OF COMPONENTS	27
ANNEXURE 3: COUNT OF ANGANWADI CENTRES.....	42
ANNEXURE 4: SELECTION OF COMPONENT	43
SOLAR FOR OPTION 1- DC SYSTEM:.....	43
SOLAR FOR OPTION 2&3: AC SYSTEM	45
LOAD WIRING	47
LUMINARIES FOR AC SYSTEM	48
NOTE *: LUMINARIES FOR DC SYSTEM.....	48
ANNEXURE 5 - DETAILS OF THE ORGANIZATION	49
ANNEXURE 6 – CONFIRMATION ON ENCLOSURES.....	50
ANNEXURE 7- SCHEDULE OF INSTALLATION.....	51
ANNEXURE 8 - PRICE SCHEDULE	52
PART A: PRICE SCHEDULE FOR CLUSTER 1.....	53
PART B: PRICE SCHEDULE FOR CLUSTER 2	53
PART C: PRICE SCHEDULE FOR CLUSTER 3	54
ANNEXURE 9: COST VARIANCE/EXTRA MATERIAL REQUEST	55
ANNEXURE 10: ESCALATION MATRIX	56
SINGLE LINE DIAGRAMS	57
CONDITIONS:	60

SELCO FOUNDATION
#690 15th Cross J P Nagar 2nd Phase
Bangalore - 560078
Telephone: 080-26493145
E-mail: procurement@selcofoundation.org

Tender: 03/2026-2027

Dated: 16/06/2026

NOTICE INVITATION TENDER

Chief Executive Officer of SELCO Foundation, Karnataka State, India hereby invites bids for Supply, Installation and Commissioning & Comprehensive maintenance of Solar Photovoltaic (SPV) off-grid systems for 1 year – for 1900 Anganwadi centres across the state of Karnataka during the year 2026-2027

1.	Tender Ref No.	03/2026-2027
2.	Last date & time for the bid submission	30-06-2026, 5:00 PM
3.	Opening date of technical bid –first cover	01-07-2026, 11:00 AM
4.	Opening date of financial bid – second cover	01-07-2026, 11:00 AM
5.	Venue of acceptance and opening of tenders.	SELCO Foundation, Bangalore
6.	Link for e-tender	https://forms.gle/WmbbLCgRBLMkoua89

Interested and eligible Organizations may furnish the Technical & Commercial Bids for Supply, Installation and Commissioning & Comprehensive maintenance of Solar Photovoltaic (SPV) off-grid systems for 1 year – for 1900 Anganwadi centres across the state of Karnataka during the year 2026-2027

<https://forms.gle/WmbbLCgRBLMkoua89>

Or;

Furnish the same to the below-mentioned address:

Procurement Officer - Tender NO 03/2026-2027
#690 15th Cross J P Nagar 2nd Phase
Bangalore - 560078
Telephone: 080-26493145

Any further information or clarification may be obtained either in person or through phone during office hours from the office of the SELCO Foundation Ph: 080-26493145 or through the email – procurement@selcofoundation.org

sd/-
Chief Executive Officer
SELCO Foundation

INSTRUCTION TO ORGANIZATION

1. Schedule of Supply, installation and commissioning:

Organization must confirm the schedule of supply, installation and commissioning which is indicated below and the same has to be confirmed through duly enclosing "Annexure 7".

Sl. No.	Scheduled activity	Within days (no. of days)
1.	Post Bidding Site Assessment	15 days
2.	Supply starts	25 days
3.	Completion of Installation and Commissioning of all the system	150 days

Note: Equipment supply can start individually and earlier than scheduled deadline. Grouting the array mount, earthing pit, and Lightning arrester work can start as early as possible. So that installation and commissioning time schedule is reduced and closure of the tender is on time. The Organization shall complete the supply schedule as per "Annexure 7" enclosed in this Bidding Documents. If the organizations wish to visit the site, they may request the same to the Procurement Officer (Selco Foundation).

2. Eligibility to Organization:

- I. The organization should be in operation for the last Five (05) years in the field of supply, installation, and maintenance of Solar Energy Solutions.
- II. Organization registration certificates or any other proof of incorporation to be submitted to establish the legal status.
- III. The organization should be able to provide excellent service. Complaints on the system should be attended within 03 days and should be resolved within 10 working days of reporting.
- IV. Preference shall be given to the organization which has its own local office, service centre and technicians at all interventional districts in KARNATAKA State during and post installation for at least 1 years.
- V. Solar panels used by the organization should be of a supplier in India and should have manufacturer valid license and evidence for the same has to be provided.
- VI. Audited Financial Statements Certified by Auditor for the last 02 years.
- VII. Income Tax returns for the last 02 financial years should be submitted.
- VIII. Organization should submit the valid PAN card & Bank Details.
- IX. The organization should submit the self-declaration certificate to declare that the organization is not blacklisted by any entity.
- X. Documents – Projects implemented
 - a. For a single cluster (ref: Annexure 3): Documents to establish that the organization has implemented projects of worth Rs. 2 Crores or more in the last financial year.
 - b. For all 3 clusters (ref: Annexure 3): Documents to establish that the organization has implemented projects of worth Rs. 6 Crores or more in the last financial year.
 - c. The decision of SELCO Foundation in this regard will be final and binding on such a organization.
- XI. The Organization shall submit Project Completion Reports for a minimum of three (3) successfully executed Solar Off-grid Projects, preferably within the State of KARNATAKA, with contact details (name, designation, phone number and/or email) of the respective client/customer for verification purposes.
- XII. The past performance of the Organization, as evidenced by the submitted project reports, shall be assessed during the technical evaluation process for shortlisting/selection of eligible Organizations.

- XIII. The quote should include AMC (ANNUAL MAINTENANCE CONTRACT) for 1 years with a minimum of 2 scheduled maintenance visits every year starting from the date of completion of installation.
- XIV. The AMC should be done with reference to the AMC calendar dates and the AMC reports shall be submitted to SELCO in the standard format.
- XV. The AMC reports shall be submitted to the concerned POC at SELCO within 7 days of the completion of AMC. The report shall contain the sign and seal from the Anganwadi centre where the AMC was conducted.

3. Cost of bidding:

The Organizations shall bear all costs associated with the preparation and submission of Bid to the Chief Executive Officer, SELCO Foundation (hereinafter referred to as “the Foundation”). The Foundation will in no case be responsible or liable for these costs, regardless of the conduct or outcome of the bidding process.

The technical proposal shall contain:

- I. Confirmation on Components as per Annexure - 4
- II. Particulars of the Firm as per Annexure - 5
- III. Checklist of Documents to be submitted in First cover as per Annexure - 6
- IV. The Organizations has to submit an acceptance letter of guarantee for 5 years for the total performance of the Solar Energy Systems.
- V. The organization should have a service centre facility in KARNATAKA State.
- VI. The Organizations have to sign all the pages of the documents as acceptance of all terms and conditions.

4. The financial bid shall contain:

The rate quoted for Solar Energy Solutions in different geographies. The rate quoted should include all taxes levied by the State & Central Govt, site assessment cost, Packing, and forwarding charges including transportation, loading & unloading, installation of Solar system, RMS, Load wiring & commissioning and annual maintenance contract for 1 years. The quote shall also include the travel cost for assessing issues, repair and replacement (spare costs to be declared up-front), labour charges etc. to fix the issues, whenever reported.

5. Price schedule:

The Organizations shall complete the price schedule as per **Annexure 8 - PRICE SCHEDULE** furnished in the Bidding Documents, indicating the total cost towards site assessment, supply and installation. SELCO Foundation will only accept the budget in the exact format outlined in Annexure 8. **Organizations can submit their bids for a single cluster or overall project as per feasibility.**

6. Fixed price:

Prices quoted by the Organizations are firm and final and binding and not subject to variation on any account. A bid submitted with an adjustable price quotation will be treated as non-responsive and rejected.

7. Pre- Bid Meeting:

Organizations can conduct pre-assessment of the sites if required at their own cost to understand and analyse the BOM or any relevant queries pertaining to tender before submitting the quotation.

A pre-bid meeting can be requested through email at **procurement@selcofoundation.org**, containing the queries, following which a meeting will be conducted either online or physically at the SELCO office on 10/06/2026. The organizations should send a questionnaire prior to meeting and attend the Prebid meeting compulsorily when informed by SELCO (no queries shall be answered on calls).

8. Period of Validity of Bids:

Bids shall remain valid for a period of 12 months from the date of opening of the Second cover (Financial Bid). A Bid valid for a shorter period shall be rejected by the Foundation as non-responsive.

9. Format and Signing of Bid:

The Organizations shall give a set of hard copies of all the documents on the sealed cover. The Bids could be submitted preferably through the online form (E-tender)

<https://forms.gle/WmbbLCgRBLMkoua89>

or submitted by hand or post/courier to the below-mentioned address

Procurement Officer - Tender No 03/2026-2027

SELCO Foundation, #690, 15th Cross, 2nd Phase,
JP Nagar, Bengaluru- 560078.

Email id: procurement@selcofoundation.org

10. Deadline for Submission of Bids:

Bids must be received by the Foundation no later than the time and date specified in the **Invitation for Bids**. The Foundation may, at its discretion, extend this deadline for submission of the bid by amending the bid Documents in which case all rights and obligations of the Foundation and Organizations previously subject to the deadline will thereafter be subject to the deadline as extended.

11. Tender Opening:

The Technical & Financial bids will be opened separately as per the date and time mentioned above. The Financial bids (Second Cover), of only technically qualified Organizations, will be opened. The Organizations Names, Bid Modifications, or Withdrawals, bid prices, Discounts and the presence or absence of the requisite details as the Foundation, at its discretion, may consider appropriate will be recorded by the Purchasing Committee of SELCO Foundation. No Bid shall be rejected at bid opening, except for late bids, which will be rejected.

12. Clarification of Bids:

During evaluation of Bids, SELCO Foundation may, at its discretion, ask the Organization for a clarification of its bid. The request for clarification and the response shall be in writing only.

13. Preliminary Examination:

The Foundation will examine the Bids to determine whether they are complete, whether any computational errors have been made, whether required sureties have been furnished, whether the documents have been properly signed, and whether the bids are generally in order.

Arithmetical errors will be rectified on the following basis. If there is a discrepancy between words and figures, the lowest of the two shall prevail and the bid shall stand corrected to that effect. The Foundation may waive any minor infirmity or non- conformity or irregularity in a bid, which does not constitute a material deviation, provided such a waiver does not prejudice or affect the relative ranking of any Organizations.

14. Acceptance or rejection of bids:

CEO, SELCO Foundation reserves the right to accept or reject any bid and to annul the bidding process and reject all bids at any time prior to award of contract, without thereby incurring any liability or any obligation to inform the affected Organizations or Organizations of the grounds for the said action.

Any Bid with incomplete information is liable to be rejected.

15. Selection of Technical Specifications, Decision on quality:

The rights of selection of technical design/ specifications and evaluation of the quality of products will be done by a team of technical experts appointed by the Procurement Committee of SELCO Foundation and their decision will be final and binding.

Organizations must submit technical information in accordance with Annexure 4 in order for their bid to be accepted. Submissions that are missing/incomplete information or have blank fields will not be considered.

16. Terms and Conditions of the Contract

- ii. **Duration:** The agreement will be valid from the date of signing the Contract and for a period 1 year (12 months) from the date of completion of the supply, installation, commissioning of Solar Photovoltaic (SPV) off-grid systems. The maintenance and service will commence from the date of completion of installation of the solar system and will be effective for a period of 1 (One) year. The end date of this agreement will be Twelve (12) months after the date mentioned in supply, installation and commissioning reports that will be subsequently annexed to this agreement and will form an integral part of this agreement.
- iii. **Post bidding assessment of the sites:** The selected Organization shall be provided with a letter of intent for the execution of the project, the details of the site will be made available to the organization. If the organization requires to conduct the site survey, they can proceed with the same and submit the report to SELCO foundation containing details of site assessment for any additional material required communicated in writing as per Annexure "9". The additional material requirements are limited to wires and MMS structure only, excluding any other materials. During assessment, the Organizations shall assess the site, feasibility of installation, BOQ (standard components + customized components) and. During the site assessment if any site is observed to be unfit (old construction, roof damage, no access to roof, under demolition, etc.) should be declared as dropout sites and it should be clearly communicated to Selco. Selco will review and provide approval for dropout/replacement of the sites.
- iv. **Process for Approval – Drop Out Anganwadi Centre:** As an outcome of the assessment, if there are any sites found to be unfit for the installation of DRE, organization shall immediately communicate to Selco along with site survey form and seek request for replacement of sites. Selco will internally review the request and provide the replacement centre.
- v. **Prices:** Prices provided by the Organization, and accepted by the Foundation shall be considered as final and firm and will not be subject to escalation due to any variations in the prices of materials, labour and/or any other reasons which may occur while the order is being carried out (except any increase in costs due to a change in applicable taxes). The Project Costs are inclusive of taxes, transport, installation and 1 year maintenance service which will include minimum two visits to the sites per year. The costs mentioned here do not include replacement of spares while servicing.

Selected organization should submit critical spare list with prices along with quotation as an annexure. Organization should consider availability in their warehouse a minimum stock of 10% inventory of critical spare, Selco will have surprise audit of this inventory.

- vi. **Payment Terms:** For the supply, installation, commissioning and comprehensive maintenance of Solar Photovoltaic (SPV) off-grid systems payment will be released in 04 tranches under each contract.
 - A. The 1st tranche of payment will be 30% paid along with the work order on submission of scheduled workplan and against submission of Invoice.
 - B. The 2nd tranche of payment will be 20% and will be paid against the supply of materials to 50% of the Anganwadi Centres or in local godown with evidence of delivery note certified by the Anganwadi Centre Authority/Foundation representative.
 - C. The 3rd tranche of payment will be 20% and will be paid against the supply of materials to 100% of the Anganwadi Centres with evidence of delivery note certified by the Anganwadi Centre Authority/Foundation representative.
 - D. The 4th and final tranche of payment will be 30% and will be paid on receipt of centre wise Installation report duly signed and certified by Anganwadi centre authority and foundation representative along with the photograph of installations mentioned in the installation report, invoices, delivery challan, AMC schedule and Submission of Bank guarantee.

- E. The Organization shall furnish a bank guarantee valid for the term of this Agreement, i.e., 5 years for a total 5% of the project cost, before the release of final payment tranche towards the service and maintenance of Solar Energy Solutions (Bank guarantee format to be verified by SELCO Foundation).
- F. Any taxes and charges such as TDS that will have to be deducted from the WO amount as per the rules in force at the time of release of payment will be done by the Foundation and the Organization will be paid only the net amount.
- G. The Organization should submit the progress report to the Program Manager- Energy for Anganwadi, SELCO Foundation who will approve the invoice for payments based on the project performance and stages of completion.
- H. The Organization has to provide installation certificate for each location mentioning the date of commissioning make & serial no. of each material (Solar panels, PCU, Battery etc.), and Photographs of the system installed before disbursal of the final instalment.
- I. The organization shall disclose the details of the State office/service centre locations with SELCO Procurement team.
- J. The organization shall maintain sufficient (10% of total systems supplied) spare parts (Shall include all possible spares that can go faulty) of critical components for a period of 5 years like, earthing cables and pipes, lightning arrestor, SPD, MCB, fuses, cables and lugs, SMPS board, IGBT, Mother board, inverter display board, static board, 4 modular board, inverter fan relay, AJB I/O connectors, etc locally within the interventional state to ease the service in a minimal downtime.

vii. Insurance:

- a. Required insurance shall be arranged and maintained by the Organization till the products/components are delivered in full till the installation is completed.
- b. Material safety after delivery: Arrangement of transport, warehouse for stocking and safekeeping of the material till the handover is within the organization 's scope of work and Foundation will not be responsible for any missing item or damage that is incurred before the system is handed over to the Anganwadi Centre authority.
- c. Accidental damage for supplied items or to delivery staff or installation staff is the responsibility of the organization and the organization will ensure required insurance coverage and damage to service staff in case of any accidents during this engagement with the Foundation.

viii. Termination Clause: Either party may terminate this contract forthwith in the event of any fraud or misconduct on part of the other party by providing a thirty-day written notice to the defaulting Party. The Foundation may terminate this contract in the event of delay in supply/ installation of the products by the Organization beyond a period of 15 days without justifiable reason from the stipulated time stated in the WO or the Organization may terminate in the event of 3 consecutive delays of 15 days from what is agreed to between the parties in making payment to the Organization in the absence of justifiable reasons intimated by writing. Any notice to be given hereunder shall be sufficiently given to the other party if forwarded by registered post or by Courier Service to the registered address of the other party mentioned in this agreement or the last known postal address of the other party or is send to the other Party's provided email. Upon the termination of this contract, the Organization shall refund the entire amount paid by the Foundation. The Organization shall deliver all deeds, documents and paper in his possession relating to the business of the Foundation and further certify the same in writing.

ix. Inspection, Checking, Testing: The products covered by the Work order shall be subject to inspection within a reasonable time after arrival at the place of delivery and the organization must facilitate this process by

fixing time informing Foundation in writing in advance and making organization representative available at the location. Besides, the Foundation is also entitled to do a preliminary inspection at the manufacturing site of the Organization by giving prior notice.

The Organization shall provide free access to the Foundation during normal working hours at Organization's or its sub-Organization's works and place at their disposal, internal test reports, material/component test certificates and approved drawings. Even if inspections and tests are fully carried out, Organization shall not be absolved to any degree from their responsibilities to ensure that products supplied, comply strictly with requirements of the Work order and technical specification at the time of delivery, inspection on arrival at site, installation and commissioning and warranty/guarantee period.

In any case, the products supplied must be strictly in accordance with the Work order and the technical specification specified by the tender failing which the Foundation shall have the right to reject goods and hold the Organization liable for non-performance of contract.

- x. **Packing:** Organization is fully responsible for adequately packing products/components mandated in the tender and ensuring appropriate packing suitable for inland carriage and ensuring complete safety of goods from any kind of damage during transport and subsequent storage at the Heath Centre authority.

- xi. **Assembly, Pre-installation survey, Installation, after sales service and training:**
 - a. The Organization shall be fully responsible for the assembly of the product at the destination site and completeness of the Project as per the Work order.
 - b. The successful organization must carry out a pre installation survey at his own cost so that the organization will have a clear idea on logistics to reach materials, estimating the ease of material movements, pre installation preparations etc.
 - c. The organization must ensure proper insulators, appropriate height and necessary grout for lightning arresters up to grounding. Any deviation has to be brought to the notice of the foundation and written/ email acceptance must be availed before adopting the deviation.
 - d. The Organization shall be fully responsible for getting the materials for grouting/preparation for foundation wherever required, curing of the grouting before installing. Organization cannot hand over this part of the work to an unskilled labourer or person in charge at the Anganwadi centre.
 - e. Organization should provide training on basic maintenance of the solar system to the designated Anganwadi centre staff.
 - f. Organization should ensure necessary guidance to the staff to maintain ethical, professionalism during the complete project with Anganwadi Centre staff, Selco Staff and any stakeholders within the project. All commercials/monetary aspect should be discussed with only Procurement Team of Selco.
 - g. Danger Boards should be provided as and where necessary as per Indian Electricity Act, 2003 and Rules, posters for DOs and DON'Ts need to be provided. At array, battery bank, distribution box, Inverter/PCU etc.
 - h. The Organization shall provide necessary "After Sales Service" at site for a period of 5 years. Organization must keep a log book at each site /to be maintained at each system location and the organization representative must record the service done/complaint recorded /resolution done /instructions if any.
 - i. Organization is solely responsible for the any type of complaints to the supplied system and complaints have to be resolved within 5 to 10 working days after lodging complaints.

- j. Complaints will be lodged using Incident Management System/SMS/WhatsApp messenger app/email or a phone call and the organization must provide the appropriate active contacts like phone number/email ID/WhatsApp number for lodging complaints. Organization shall respond to the complaint and assist SELCO team to close the issues reported within 5 to 10 working days after lodging the Complaints.
 - k. Active contact numbers will be displayed at the site prominently for registering any complaints on the performance of the product.
 - l. The organization shall depute a dedicated service team at the local level of the concerned state and district for the troubleshooting/repair/replacement/service assistance for a period of 5 years. A point of contact and the escalation matrix shall be notified to SELCO Foundation along with the tender document, any further changes to the POC or the escalation matrix shall be informed to SELCO within 24 hours of such change. Organization should share the Escalation matrix of their organization up to as per annexure "10".
 - m. The organization should have in-house capacity to execute the assignment that meets the project's requirements. At any given point of time, if there arises a need of subcontracting the work, Organization should communicate to Selco and get prior approval along with the details of sub-contractor team from Selco. Ensuring quality work from subcontractor will be the sole responsibility of the organization.
 - n. The Organization has to submit a plan of servicing to the Foundation before the release of final payment. The organization will arrange a minimum of two (2) visits per year to the site for scheduled maintenance (AMC) for a period of one (1) years and submit a written report to the Foundation on the servicing with a functioning status of each site every six months.
- xii. **Delivery terms:**
- a. Successful organization will be provided a detailed written communication on site address, system to be installed and a brief site profile for installation and necessary contacts.
 - b. The delivery of the said products will be to the Anganwadi Centre authority as per the list provided by the Foundation in writing. No variation shall be permitted, except with prior authorization in writing from the Foundation.
 - c. Delivery Schedule and terms will be as per the WO. In case of a delay solely attributed to the organization in meeting the said deliverables, the Organization shall be liable to pay a late fee at the rate of 2% per week beyond a period of 30 days and up to a maximum of 10% of the value of this Agreement.
- xiii. **Risk Purchase on Default:** In case of default on the part of the Organization to supply all the products or part thereof covered by the contract as per the standard/specifications within the contractual delivery period stipulated in the contract, the Foundation shall have the right to purchase such products or other of similar description at the risk and cost of the Organization. Organization shall be liable to pay the cost of such purchase products and also the penalty under clause 8 above for resultant delay.
- xiv. **Delay due to force majeure:** If any time during the continuance of the Agreement the performance of either party in whole or part of any obligation under the contract shall be prevented or delayed by reason of any war, hostility, explosions, epidemics, quarantine restrictions, or other acts of God, then provided, notice of the happening of any such event is given by either party to the other within fifteen (15) days from the date of occurrence thereof. Either party shall be entitled to terminate this contract if such Force Majeure event persists for a period of ninety (90) days and neither party has any claim for damages against the other in respect of such non-performance and delay in performance and deliveries under the contract. All duties and

responsibilities of the Parties shall be resumed as soon as practicable after such event has come to an end or ceased to exist. Force Majeure conditions shall not affect the payment obligations of the Foundation which shall be made as per clause 3 of this Agreement.

- xv. **Rejection, Removal of Rejected Goods and Replacement:** In case the testing and inspection at any stage by inspectors reveal that the product, material and workmanship do not comply with the agreed specifications and requirements, the same shall be removed by the Organization at his/its own expenses and risk within 15 to 20 working days of written information of rejection by the Foundation. The Foundation shall be at liberty to dispose of such rejected goods in such manner as they may think appropriate, in the event the Organization fails to remove the rejected goods within the period as aforesaid. All expenses incurred by the Foundation for such disposal shall be payable by the account of the Organization. The freight paid by the Foundation, if any, on the inward journey of the rejected material shall be reimbursed by the Organization to the Foundation before the rejected materials are removed by the Organization. The Organization will have to proceed with the replacement of that product or part of the product without claiming any extra payment if so, required by the Foundation, within 2 weeks of notification.
- xvi. **Warranty:** The Organization shall warrant that every material/product to be supplied shall be in accordance with the specifications agreed upon by both parties. The items should be consistent with the established, recognized or stipulated standards for material of the type usually used for the purpose and in full conformity with the specifications and drawings or samples, if any, outlined by the Foundation in the tender documents and agreed upon by the Organization by the virtue of acceptance of the WO by the organization. Products offered must withstand normal operating conditions. The warranty shall continue notwithstanding inspection, payment, acceptance of tendered product and shall expire except in respect of complaints notified to Organization prior to such date within 60 months from the date of commissioning. The warrant will be according to manufacturer's warranty policies. The organization shall submit the original warranty cards containing the warranty clauses to the Anganwadi centre and a copy of the same along with installation report to SELCO Foundation against all the products installed (Inverter, panel, battery).
- xvii. **Performance Guarantee:** The Organization shall guarantee that any/all material used in execution of the Work Order shall be in strict compliance with characteristics requirements and specifications agreed upon. The Organization shall guarantee that all material and products shall be repaired or replaced, as the case may be, at his own expense in case the same have been found to be defective in respect of material, workmanship for smooth and rated operation within a period of 60 months from the date of commissioning. Acceptance by the Foundation of any product and materials or their replacement will not relieve the Organization of his/its responsibility concerning the above guarantee. In case of any legal case against the Foundation by any ultimate user of the product with respect to the performance of the system (during the warranty period), the Foundation shall not be held liable in such cases and the Organization should support the Foundation with required and relevant technical testing and reports supporting the performance of the product and to defend that the non-performance of the product is not because of any manufacturing defect. The warranty replacements will be made within 10 working days from the date of receipt of the Complaint at the site.
- xviii. **Saura-eMitra Platform and Organization Responsibilities**
1. **Saura-eMitra Platform**

The Saura-eMitra platform, developed by SELCO Foundation, shall be used for tracking installation data, managing annual maintenance activities, and monitoring issue reporting and resolution of Solar Systems across Anganwadi facilities. Organizations are required to actively use this platform for all related activities.
 2. **Installation and Quality Checks**
 - o Organizations must ensure that all technicians and supervisors install and use the Field Assist Android App.

- All installation asset data and reports must be submitted via the app.
- Quality checks will be conducted based on submitted data.
- Organizations are responsible for rectifying any issues identified by SELCO Foundation representatives after reviewing installation reports.

3. Annual Maintenance

- Organizations shall conduct annual maintenance and update all relevant data in the Field Assist App.
- AMC reports will be centrally evaluated and approved by the designated team.

4. Issue Reporting and Resolution

- All issues related to DRE systems in Anganwadi facilities must be reported through the Saura-eMitra platform.
- Organizations will be notified when an issue is assigned.
- The Organization's Point of Contact (PoC) must access the platform, review assigned issues, and act within agreed Service Level Agreements (SLAs) or Escalation matrix as per Annexure 10:
 - HIGH priority: within 3 days
 - MEDIUM priority: within 7 days
 - LOW priority: within 10 days
- Once resolved, the Organization PoC must update the issue status in the platform.
- SLA breaches will result in penalties.

5. Out of Warranty Cases and Spare Parts

- For out-of-warranty cases, Organizations must resolve issues within 14 days of receiving a work order via the Saura-eMitra platform.
- For spare part changes, Organizations must resolve issues within 7 days of updating the status as "Spare parts change."
- Failure to meet timelines requires Organizations to update both SELCO Foundation and Anganwadi staff via the platform.

6. Organization Responsibilities

- Organizations must assign a dedicated PoC to manage the app and resolve issues.
- The PoC must attend regular training sessions conducted by SELCO Foundation.
- The PoC is responsible for updating issue statuses within timelines.
- If the PoC is unresponsive or fails to update statuses, escalations will be sent to Organization leadership for corrective action.

xix. **Indemnity:** The Organization shall at all times indemnify and hold the Foundation harmless against all claims which may be made in respect to infringement of any right protected by patent, registration of design or trademark or other intellectual property, whether registered or not. Provided always that in the event of any claim in respect of alleged breach of patent, registered designs or trademark and other intellectual property whether registered or not, being made against the Foundation, the Foundation shall notify the Organization of the same and the Organization shall indemnify and hold the Foundation harmless at his own expense either settle any such dispute or conduct any litigation that may arise there from.

The Organization shall, indemnify, defend and hold the Foundation and its officers, directors, representatives and assigns harmless from and against any liability or any other loss that may occur, arising from or relating to a breach or misrepresentation of any of the terms or obligations under this Contract or any acts, errors, representations, fraudulent acts, misrepresentations, wilful misconduct or negligence of the Organization its employees, sub organizations and agents in performance of its obligations under this Contract.

- xx. **Child Labor:** The Organization will ensure that, its parent entities, partners or subcontractors nor any of its subsidiary or affiliated entities (if any) is engaged in any practice inconsistent with the rights set forth in the Child Labour (Prohibition and Regulation) Act of 1986, which, inter alia, requires that a child shall be protected from performing any work that is likely to be hazardous or to interfere with the child's education, or to be harmful to the child's Health or physical, mental, spiritual, moral, or social development
- xxi. **Forced Labor:** The Organization will not engage in any activity that will result in forced or compulsory labor stated under applicable laws including the Bonded Labour System (Abolition) Act, 1976,
- xxii. **Abuse of Labor:** Organization will act in accordance with applicable laws and regulations in relation to labourers rights as stated in The Factories Act, 1948 and similar legislations.
- xxiii. **Working Hours, Overtime, Wages and Other Benefits:** Working hours, wages and benefits shall be provided by the Organization to its staff and employees in accordance with applicable laws including the Minimum Wages Act, 1948.
- xxiv. **Declaration of blacklisting:** The Organization represents and warrants to SELCO that, as on the date of signing of this Purchase Order, it is neither blacklisted/ debarred nor it is under a declaration of ineligibility by Central / State or Semi-Government Organization/Department or Institutions and Public Sector Undertakings in India and abroad. The Organization further undertakes to duly inform SELCO in writing in the event it is blacklisted subsequent to execution of this Purchase Order.
- xxv. **Compliance with Anti-bribery Laws:** The Organization and each of its directors, officers, employees, agents or other (collectively referred to as "Organization") represent and warrant that it shall not either directly or on behalf of SELCO Foundation give, offer, promise to offer, or authorize the offer, directly or indirectly (proxy bribing), anything of value (such as money, shares, goods or service, gifts or entertainment) to government officials, government customers, potential government customers or foreign government officials including officials of any public international organizations or officials of any political party either in India or abroad ("Officials") with an Intent to influence any act or decision in his or her official capacity Induce the Official to do or omit to do any act in violation of his or her lawful duty to obtain any improper advantage, or Induce to use such Official 's influence improperly to affect or influence an act or decision.
The Organization shall not provide any offering, promising, giving or receive, solicit or accept a financial or other advantage, or any other thing of value, with the intention of influencing or rewarding the behaviour of a person in a position of trust to perform a public, commercial or legal function to obtain or retain a commercial advantage.
The Organization understands and acknowledges that any non- adherence to the warranty as stated herein above will be violation of the provisions of the Indian Prevention of Corruption Act,1988 and other applicable laws and legislations ("Anti-bribery Laws").
In addition, the Organization agrees to promptly report to SELCO Foundation of any incident of breach or potential breach of this section.
- xxvi. **Compliance with Sexual Harassment of Women (Prevention, Prohibition & Redressal) Act, 2013 (PoSH):** The Organization shall agree to adhere to the mandates prescribed under the Sexual Harassment of Women (Prevention, Prohibition & Redressal) Act, 2013, which requires all workplaces to have a Policy and Internal Committee to address complaints of sexual harassment that women may face at the workplace.
- xxvii. **Other Clauses:**
 - a. The Parties will treat all information disclosed to it by the other Party under this agreement as information with proprietary value and will not disclose the same to any outsiders or use any such

information, either directly or indirectly, in whole or in part, for any commercial or non-commercial purposes. The Parties will not at any time, except under legal process, divulge any trade or business secret relating to the other Party or any customer or agent of the other Party, which may become known by virtue of the position under the agreement.

- b. All information that is developed during the Term in relation to the Project which shall include but not be limited to information collected through the remote monitoring system and other information, shall solely belong to the Foundation.
- c. Except as is otherwise expressly provided in writing in the agreement, the Foundation shall be entitled to all intellectual property and other proprietary rights including, but not limited to, patents, copyrights, and trademarks, with regard to products, processes, inventions, ideas, know-how, or documents and other materials which the Organization has developed for the Foundation under the agreement and which bear a direct relation to or are produced or prepared or collected in consequence of, or during the course of, the performance of the agreement. The Organization acknowledges and agrees that such products, documents and other materials constitute works made for hire by the Foundation.
- d. Subject to the foregoing provisions, all documents, reports, recommendations, documents, and all other data compiled by or received by the Organization under the agreement shall be the property of the Foundation, shall be made available for use or inspection by the Foundation at reasonable times and in reasonable places, shall be treated as confidential, and shall be delivered only to the Foundation's authorized officials on completion of work under the agreement.
- e. Both the Foundation and the Organization fully and freely intend to create an independent contractor relationship under this Agreement. Nothing herein shall be deemed to establish a partnership, joint venture, association or employment relationship between the parties. Both parties agree that the Organization has the right to control the manner and means employed in performing their activities under this Agreement. The Organization shall update and inform the Foundation in writing of the various methods used to perform such activities in a timely manner. The Foundation shall further have the right to provide suggestions and direct the Organization to use other methods or refrain from using certain methods when performing such activities.
- f. The Foundation represents and warrants that (a) it has the full right and authority to enter into this Agreement, and no consent or authorization not obtained prior to the Effective Date is necessary to be obtained, (b) the Foundation is a charitable trust registered under the laws of India and is authorized to do business to the extent necessary to fulfill its obligations hereunder.
- g. This agreement shall not be amended or renewed, except in writing mutually agreed by both parties. The project shall be fully completed as agreed in the above-mentioned terms and conditions.
- h. Not with standing anything else to the contrary: -
 - Organization 's total aggregate liability under this Agreement shall not in any case exceed 100% of the value of this Agreement;
 - neither party shall be liable for any indirect, consequential, special, remote, exemplary, punitive or speculative losses or any losses or damages for loss of profits or business even if such party has been advised of the possibility of such costs or damages; and
 - The Organization shall have no liability for matters outside of its own scope of works.

- i. In the event that any or any part of the provisions contained in this Agreement is determined to be invalid, unlawful or unenforceable to any extent, such provision shall be severed from the remaining provisions which shall continue to be valid and enforceable to the fullest extent permitted by law.
- j. The Foundation shall not either directly or indirectly assign, transfer, charge or in any manner make, offer or purport to assign, transfer or charge this Agreement or any rights herein or any part thereof without the previous consent in writing of the Organization.
- k. Neither Parties shall during the term of this Agreement and for a period of one (1) year thereafter, either directly or indirectly, through any Third Party (ies) recruit, solicit, discuss employment with, hire, employ or induce any such individual to leave the employment of the other Party, unless prior written consent is obtained from the Party.
- l. Neither Party shall make any announcement relating to this Contract or any matter arising in respect of this or its relationship with the other Party, without the prior written consent of the other Party, which consent will not be unduly withheld.
- m. Parties shall not use any trademark, trade name, service mark, service name, copyright, logo or other intellectual property of the other Party without the prior written consent of such Party. For avoidance of doubt, Parties shall seek prior written consent each time when it intends to use trademark, trade name, service mark, service name, copyright, patent, or logo of the other Party.

xxviii. Governing Law and Arbitration:

The Parties agree that this Agreement shall be governed and construed in accordance with the laws of India. The Parties hereto agree that they shall use all reasonable efforts to resolve between themselves any disputes, controversy or claim arising out of or relating to this Agreement. If the Parties fail to resolve the matter within the 60 days of occurrence of any dispute, such dispute, controversy or claim shall be settled by binding arbitration under the Indian Arbitration and Conciliation Act, 1996. There shall be one arbitrator mutually appointed by the Parties. The place of arbitration shall be Bangalore and the arbitration proceedings shall be in English. The courts at Bangalore alone shall have the jurisdiction to entertain and, or try any dispute arising out of or in connection with or in relation to the terms of this Agreement.

ANNEXURE 1: TECHNICAL SPECIFICATIONS OF SOLUTIONS

Anganwadi Option 1: DC System

Bill of Material for Solar System

Sl.No	Products	Capacity	UoM	Qty
1	Solar Module	Solar Photovoltaic Array of Total Minimum Capacity 125 Wp Panel Manufacturer should be approved under MNRE ALMM List	Nos	2
2	Solar Battery	Valve regulated lead-acid (VRLA) battery - 100 Ah @ 12 V, C – 10 (Battery terminal caps used, must be big enough to cover the entire terminal area and the nut bolt assembly. Also, spring washers to be used at each battery terminal).	No	1
3	Module Mounting Structure (MMS*)	Solar PV Module support structure. RCC Roof: GI based (120 microns), C-section purlins, rafters and legs of minimum 3 mm thickness. End clamps & mid clamps of Anodized Aluminum, SS nut-bolt assembly. Civil work to be made at each respective legs, and of minimum size, 1 feet by L x B x H, and to be cured for 3 consecutive days It should withstand the wind speed of 100 – 150 km/hr It should be suitable for above mentioned solar module - As per Sl.No. 1 Inclined Tin Sheet roof: Mini rails of the following specifications are to be incorporated. Anodized aluminium(70 Microns) L x H x W x T – 300mm x 100mm x 40mm x 2 mm EPDM tapes with adhesion to be used for each mini rail.	Set	1
4	Solar Charge Controller (CCU)	20 A, 12 Vdc with dedicated load port. (Wall Mount with base plate)	No	1
5	Copper Cable Red+Black (Module – CCU) - PV1- F (Solar Cables)	4 sq.mm UV Protected Cable	Mtrs	30
6	Copper Cable (Battery - CCU) - (DC Cables)	10 Sq.mm (Tin-coated copper lugs with insulation to be used at each battery terminal).	Mtrs	10
7	Battery trolley box with wheels - Hard Plastic	For 100 Ah, 12 V - 1 No	Set	1
8	MC4 Connector	Male and Female	Set	1
9	MC4 Connectors – Y branch	Male and Female	Set	1
10	Double Pole MCB (load Side) with Conduit box	20 A, 250 Vdc	No	1
11	Single Line Diagram - (SLD) for the system	Sun board with 3 mm Thickness - 2 ft x 1.5 ft	No	1
12	Do's and Don'ts Practices Poster (Solar Panels, Battery and CCU)	Foam Plaque - A4 Size for each	No	1

13	Signboard for Danger, No Fire and PASS	Danger, Electric shock, No Fire, PASS	No	1
14	Fire Extinguisher	Multi Purpose - ABC Dry powder extinguishing agents (or) CO2 type with 2 kg net weight of the charge inside the cylinder.	No	1
15	Metallic Enclosure with Isolator's having minimum gap of 1 inch. (PV and Battery)	1st MCB for Battery Input - 25 A, 250 Vdc, Double Pole 2nd MCB for PV Input – 20 A, 250 Vdc, Double Pole	Set	1
16	Consumables	Includes: UPVC pipes and fittings, Flexible pipes, Screws, Cable lugs, Nuts and Bolts etc....	Set	1

Bill of Material for Load Wiring:

Sl.no	Item	Description	UoM	Qty
1	Switch (Modular)	6 A, 1-Way (White colour).	Nos	8
2	Socket (Modular)	2 pin, 6 A (White colour).	Nos	2
3	USB Port for mobile charging	Input Voltage - 12 Vdc (Max - 25 Watt) , Modular and fit in to	Nos	1
4	Cables - For Load Connection (Red)	1.5 Sq. mm, EFFR copper cables. (Interconnecting switchboards with loads)	Mtrs	30
	Cables - For Load Connection (Black)	1.5 Sq. mm, EFFR copper cables. (Interconnecting switchboards with loads)	Mtrs	30
5	Power Cable - From CCU to Room (Red)	2.5 Sq. mm, EFFR copper cables. (Interconnecting distribution box with switchboards)	Mtrs	20
	Power Cable - From CCU to Room (Black)	2.5 Sq. mm, EFFR copper cables. (Interconnecting distribution box with switchboards)	Mtrs	20
6	Ceiling Rose	FR polycarbonate outer housing with ducts, Inner metal ring with high conductive brass terminals (White colour).	Nos	5
7	Angle holder	FR polycarbonate outer housing with ducts, Inner metal ring with high conductive brass terminals (White colour).	Nos	3
8	1 modular Switch Box with plate	Surface mounting type, ABS material with brass studs, Provision for conduits. (White colour)	Nos	3
9	2 modular Switch Box with plate	Surface mounting type, ABS material with brass studs, Provision for conduits. (White colour)	Nos	1
10	3 modular Switch Box with plate	Surface mounting type, ABS material with brass studs, Provision for conduits. (White colour)	Nos	1
11	Modular Box Blank plate (Dummy)	Dummy Modular	Nos	3
12	UPVC Conduit Pipe (White)	Polypropylene material, 20 mm diameter, White colour, Flame retardant, Anti- distortion.	Nos	18
13	UPVC Conduit Tee Joint	UPVC pipe (White color), 20 mm diameter, Flame retardant, Low halogen, Low smoke, Smoke suppressing, Temperature stable.	Nos	5
14	UPVC - Short & Long Elbow (White)	UPVC material, 20 mm diameter, White colour, Flame retardant, Low halogen, Low smoke, Smoke suppressing, Temperature stable. "	Nos	8
15	2way Junction Box	UPVC material, 20 mm diameter, White colour, Flame retardant, Low halogen, Low smoke, Smoke suppressing, Temperature stable.	Nos	4

16	3way Junction Box	UPVC material, 20 mm diameter, White colour, Flame retardant, Low halogen, Low smoke, Smoke suppressing, Temperature stable.	Nos	4
17	Square Box		Nos	4
18	Plastic wall lug	UPVC material, Size - 35 x 8 mm, Crack- proof, White colour, Eco-friendly.	Pack	1
19	Screw	Stainless steel/Galvanized Iron - rust-free material, Size - 35 x 8 mm, Flat head with deep slot.	Pack	1
20	Electrical Insulating Tape	Size - 18 x 0.125 mm, High insulating resistance, Moisture & Corrosion resistant, Flame-retardant, Long-lasting adhesion.	Nos	2
21	Pipe Saddle Clamps	UPVC material, Size: 20 mm diameter, Light duty pipe clamp, Single nail.	Nos	55
22	Saddle Nail	Concrete nail Size - 1.5 inch GI/ Astel string steel	kg	0.6
23	Cable Tie	Polypropylene Material, Size – 150 mm, White Colour.	Packs	1
24	Cable Lugs - 1	2.5 Sq.mm, Pin-type, Tin-coated copper.	Nos	6
25	Flexible Pipe	Polypropylene material, 20 mm diameter, White colour, Flame retardant, Anti- distortion.	Mtrs	5
26	Labelling Tags (Cables & Loads identification tags)	Size - 3 x 1 Inch, Synthetic paper, Self- adhesive, Fluorescent Green colour, Waterproof, Temperature resistant.	Pack	1

Note*:

Installation of Luminaires-DC (for Anganwadi Option 1: DC System) supplied by SELCO or any third party (as communicated by SELCO) shall be the sole responsibility of the Organisation. Installation charges shall be quoted separately, included in the financial bid. This provision shall be binding upon award of the contract.

Anganwadi Option 2: AC System -With Full wiring

Bill of Material for Solar System

Sl. No	Products	Capacity	UoM	Qty
1	Solar Module	Solar Photovoltaic modules of Minimum Capacity 630 Wp (TOPCON)N-Type Panel Make and Model should be approved under MNRE ALMM List	No	1
2	Solar Battery	Valve regulated lead-acid (VRLA) battery – 150 Ah @ 12 V, C – 10 (Battery terminal caps used, must be big enough to cover the entire terminal area and the nut bolt assembly. Also, spring washers to be used at each battery terminal).	No	1
3	Module Mounting Structure (MMS)	Solar PV Module support structure. RCC Roof: Lower elevation/Landscape Orientation (Triangular MMS with concrete block). Inclined Tin Sheet Roof: Mini rail of the following specifications are to be incorporated Anodized aluminium(70 Microns) L x H x W x T – 300mm x 100mm x 40mm x 3mm EPDM tapes with adhesion to be used for each mini rail. Self drilling screws of 2 inches to be used for metal purlins and 3 inches to be used for wooden purlins.	Set	1

		Or Triangular MMS(Landscape mode) with EPDM tapes for south orientation. It should withstand the wind speed of 200 – 250 km/hr. It should be suitable for above mentioned solar module - As per Sl.No. 1		
4	Solar Inverter/PCU - 230 Vac, 50 Hz	Total Minimum Capacity 1 kVA, 12 V – MPPT based Single Phase	No	1
5	Change over switch / Bypass Switch (PCU -Grid - Solar Loads)	16 A, 230 Vac (Single Phase)	No	1
6	Copper Cable Red+Black (Module - AJB) - PV1-F (Tin Coated Solar Cables)	6 sq.mm UV Protected Cable (Tin-coated copper lugs with insulation to be used at each termination points).	Mtrs	20
7	Copper Cable Red + Black (AJB - Inverter) - (Tin Coated DC Cables)	6 sq.mm	Mtrs	6
8	Copper Cable (Red + Black) (Battery - Inverter) - (Tin Coated DC Cables)	PCU comes with inbuilt cables for battery	NA	NA
10	Earthing Cable for COS	1 Sq.mm Grounding Lugs should be used. (Tin-coated copper lugs with insulation to be used at each termination points).	Mtrs	4
11	Earthing Cable (MMS + Lightning Arrestor + AJB + GIPB + Inverter)	16 Sq.mm (Tin-coated copper lugs with insulation to be used at the cable-earth electrode interface).	Mtrs	22
13	Earthing Kit: (MMS + LA + AJB + GIPB + Inverter+ Changeover Switch)	Chemical earthing powder (50 kg per pit). Copper Bonded Electrode – Minimum 48 mm diameter, 1000 mm long with 250 microns Bonding thickness, tin-coated copper lugs with insulation, SS clamps with SS nut-bolts assembly. protective FRP Chamber with lid should be made. Earthing pit size should be minimum of 6-inch diameter and 1.5-meters long and should be filled with back fill compound. 1 x Copper Busbar of 6-inch long, 5-hole, 3 mm thick	Set	1
14	Lightning Protection System	Lightning arrestor Solid Aluminium Alloy of 15 mm diameter and 2000 mm long with base plate with Insulator should be used. Bore clamp to be used to interconnect lightning arrestor and down conductor.	Set	1
15	Grid Input Protection Box with SPD and MCB	MCB Rating: 230 Vac, 16 A (Double Pole) SPD Rating: 275 Vac, Type 2, 40 kA (Double pole with indicators) Inter connection of the components inside the GIPB should be 2.5 Sq.mm (Tin-coated copper lugs with insulation to be used at each termination points).	No	1
16	Battery trolley box with wheels - Hard Plastic , Electrical Insulation mat (Minimum 0.4 kV)	As per Solar Battery Sl. No. - 2	Set	1

17	Solar Array Junction Box with MCB and SPD.	1 IN 1 OUT MCB Rating: 500 Vdc, 25 A (Double Pole) SPD Rating: Uc - 65 Vdc, Type 2, 40 KA (Double pole with indicators) Inter connection of the components inside the AJB should be DC cable of 6 Sq.mm	No	1
18	Marking for earthing with Elevated Plaques	Elevation pole length - 3 Feet. Metal plaque dimension - A5	No	1
19	Single Line Diagram (SLD) for the system	Sun board with 3 mm Thickness - 2 ft x 1.5 ft	No	1
20	Do's and Don'ts Practices Poster (Solar Panels, Battery and Inverter)	Foam Plaque - A4 Size for each	No	1
21	Signboard for Danger, No Fire and PASS	Danger, Electric shock, No Fire, PASS	No	1(Each)
22	I/P and O/P wiring of Grid Connection (Red + Black) - AC cable	2.5 Sq. mm. (Tin-coated copper lugs with insulation to be used at each termination point).	Mtrs	2
23	Fire Extinguisher	Multi-Purpose - ABC Dry powder extinguishing agents (or) CO2 type with 3 kg net weight of the charge inside the cylinder.	No	1
24	Load MCB	6 A, 230 Vac (Double Pole)	Set	1
25	Combo Switch socket with box and Plate (For Grid Input)	6 A, 230 V	No	1
26	3 Pin Top (For Inverter Output)	6 A, 230 V	No	1
27	Metallic Enclosure for Solar Inverter and Battery	Metallic Enclosure for Solar Inverter and Battery – Electric shock proof, Rust resistant, small diamond grill mesh, knife proof with door and lock, Size – (L x W x H) - 3 Feet x 3 Feet x 4 Feet	No	1
28	Consumables	Includes: UPVC pipes and fittings, Flexible pipes, Screws, Nuts and Bolts, Cable lugs etc...	Set	1

Bill of Material for Luminaries:

Sl.no	Products	Capacity	UoM	Qty
1	LED Tube light	20 W, 230 Vac	Nos	2
2	LED Bulb	9 W, 230 Vac	Nos	3
3	Wall Mounted Fan	55 W, 230 Vac	Nos	2

Bill of Material for Load Wiring:

Sl.no	Item	Description	UoM	Qty
1	Socket (Modular)	2 pin, 6 A, 230 V, (White colour).	Nos	2
2	Socket (Modular)	3 pin, 6 A, 230 V, (White colour).	Nos	2
3	Switch (Modular)	6 A, 1-Way, 230 V, (White colour).	Nos	9
4	Power Cable - 1 (Red)	1.5 Sq. mm, EFFR copper cables. (Interconnecting switchboards with loads)	Mtrs	40
	Power Cable - 1 (Black)	1.5 Sq. mm, EFFR copper cables. (Interconnecting switchboards with loads)	Mtrs	40

5	Earthing Cable (Green)	1 Sq. mm, EFFR copper cables. (Interconnecting earth pin (3-pin sockets) with MET)	Mtrs	10
6	Ceiling Rose	6 A, 230 V, FR polycarbonate outer housing with ducts, Inner metal ring with high conductive brass terminals (White colour).	Nos	5
7	Angle Holder	6 A, 230 V, FR polycarbonate outer housing with ducts, Inner metal ring with high conductive brass terminals (White colour).	Nos	3
8	1 modular Switch Box with plate	Surface mounting type, ABS material with brass studs, Provision for conduits. (White colour)	Nos	3
9	2 modular Switch Box with plate	Surface mounting type, ABS material with brass studs, Provision for conduits. (White colour)	No	1
10	3 modular Switch Box with plate	Surface mounting type, ABS material with brass studs, Provision for conduits. (White colour)	Nos	5
11	Modular Box Blank plate (Dummy)	Dummy Modular	Nos	3
12	UPVC Conduit Pipe (White)	Polypropylene material, 20 mm diameter, White colour, Flame retardant, Anti-distortion.	Nos	15
13	UPVC Conduit Tee Joint	UPVC pipe (White color), 20 mm diameter, Flame retardant, Low halogen, Low smoke, Smoke suppressing, Temperature stable.	Nos	5
14	UPVC - Short & Long Elbow (White)	UPVC material, 20 mm diameter, White colour, Flame retardant, Low halogen, Low smoke, Smoke suppressing, Temperature stable."	Nos	10
15	2way Junction Box	UPVC material, 20 mm diameter, White colour, Flame retardant, Low halogen, Low smoke, Smoke suppressing, Temperature stable.	Nos	4
16	3way Junction Box	UPVC material, 20 mm diameter, White colour, Flame retardant, Low halogen, Low smoke, Smoke suppressing, Temperature stable.	Nos	4
17	4way Junction Box	UPVC material, 20 mm diameter, White colour, Flame retardant, Low halogen, Low smoke, Smoke suppressing, Temperature stable.	Nos	4
18	Square Box		Nos	8
19	Plastic wall lug	UPVC material, Size - 35 x 8 mm, Crack-proof, White colour, Eco-friendly.	Packs	1
20	Screw	Stainless steel/Galvanized Iron - rust-free material, Size - 35 x 8 mm, Flat head with deep slot.	Packs	1
21	Electrical Insulating Tape	Size - 18 x 0.125 mm, High insulating resistance, Moisture & Corrosion resistant, Flame-retardant, Long-lasting adhesion.	Nos	2
22	Pipe Saddle Clamps	UPVC material, Size: 20 mm diameter, Light duty pipe clamp, Single nail.	Nos	45
23	Saddle Nail	Concrete nail Size - 1.5 inch GI/ Astel string steel	kg	0.5
24	Cable Tie	Polypropylene Material, Size – 150 mm, White Colour.	Packs	1
25	Cable Lugs - 1	1.5 Sq.mm, Pin-type, Tin-coated copper.	Nos	5
26	Flexible Pipe	Polypropylene material, 20 mm diameter, White colour, Flame retardant, Anti-distortion.	Mtrs	5
27	Labelling Tags (Cables & Loads identification tags)	Size - 3 x 1 Inch, Synthetic paper, Self-adhesive, Fluorescent Green colour, Waterproof, Temperature resistant.	Pack	1

Anganwadi Option 3: AC System- With Load Segregation

Bill of Material for Solar System

Sl. No	Products	Capacity	UoM	Qty
1	Solar Module	Solar Photovoltaic modules of Minimum Capacity 630 Wp (TOPCON)N-Type Panel Make and Model should be approved under MNRE ALMM List	No	1
2	Solar Battery	Valve regulated lead-acid (VRLA) battery – 150 Ah @ 12 V, C – 10 (Battery terminal caps used, must be big enough to cover the entire terminal area and the nut bolt assembly. Also, spring washers to be used at each battery terminal).	No	1
3	Module Mounting Structure (MMS)	Solar PV Module support structure. RCC Roof: Lower elevation/Landscape Orientation (Triangular MMS with concrete block). Inclined Tin Sheet Roof: Mini rail of the following specifications are to be incorporated Anodized aluminium(70 Microns) L x H x W x T – 300mm x 100mm x 40mm x 3mm EPDM tapes with adhesion to be used for each mini rail. Self drilling screws of 2 inches to be used for metal purlins and 3 inches to be used for wooden purlins. Or Triangular MMS(Landscape mode) with EPDM tapes for south orientation. It should withstand the wind speed of 200 – 250 km/hr. It should be suitable for above mentioned solar module - As per Sl.No. 1	Set	1
4	Solar Inverter/PCU - 230 Vac, 50 Hz	Total Minimum Capacity 1 kVA, 12 V – MPPT based Single Phase	No	1
5	Change over switch / Bypass Switch (PCU -Grid - Solar Loads)	16 A, 230 Vac (Single Phase)	No	1
6	Copper Cable Red+Black (Module - AJB) - PV1-F (Tin Coated Solar Cables)	6 sq.mm UV Protected Cable (Tin-coated copper lugs with insulation to be used at each termination points).	Mtrs	20
7	Copper Cable Red + Black (AJB - Inverter) - (Tin Coated DC Cables)	6 sq.mm	Mtrs	6
8	Copper Cable (Red + Black) (Battery - Inverter) - (Tin Coated DC Cables)	PCU comes with inbuilt cables for battery	NA	NA
10	Earthing Cable for COS	1 Sq.mm Grounding Lugs should be used. (Tin-coated copper lugs with insulation to be used at each termination points).	Mtrs	4

11	Earthing Cable (MMS + Lightning Arrestor + AJB + GIPB + Inverter)	16 Sq.mm (Tin-coated copper lugs with insulation to be used at the cable-earth electrode interface).	Mtrs	22
13	Earthing Kit: (MMS + LA + AJB + GIPB + Inverter+ Changeover Switch)	Chemical earthing powder (50 kg per pit). Copper Bonded Electrode – Minimum 48 mm diameter, 1000 mm long with 250 microns Bonding thickness, tin-coated copper lugs with insulation, SS clamps with SS nut-bolts assembly. protective FRP Chamber with lid should be made. Earthing pit size should be minimum of 6-inch diameter and 1.5-meters long and should be filled with back fill compound. 1 x Copper Busbar of 6-inch long, 5-hole, 3 mm thick	Set	1
14	Lightning Protection System	Lightning arrestor Solid Aluminium Alloy of 15 mm diameter and 2000 mm long with base plate with Insulator should be used. Bore clamp to be used to interconnect lightning arrestor and down conductor.	Set	1
15	Grid Input Protection Box with SPD and MCB	MCB Rating: 230 Vac, 16 A (Double Pole) SPD Rating: 275 Vac, Type 2, 40 kA (Double pole with indicators) Inter connection of the components inside the GIPB should be 2.5 Sq.mm (Tin-coated copper lugs with insulation to be used at each termination points).	No	1
16	Battery trolley box with wheels - Hard Plastic Electrical Insulation mat (Minimum 0.4 kV)	As per Solar Battery Sl. No. - 2	Set	1
17	Solar Array Junction Box with MCB and SPD.	1 IN 1 OUT MCB Rating: 500 Vdc, 25 A (Double Pole) SPD Rating: Uc - 65 Vdc, Type 2, 40 KA (Double pole with indicators) Inter connection of the components inside the AJB should be DC cable of 6 Sq.mm	No	1
18	Marking for earthing with Elevated Plaques	Elevation pole length - 3 Feet. Metal plaque dimension - A5	No	1
19	Single Line Diagram (SLD) for the system	Sun board with 3 mm Thickness - 2 ft x 1.5 ft	No	1
20	Do's and Don'ts Practices Poster (Solar Panels, Battery and Inverter)	Foam Plaque - A4 Size for each	No	1
21	Signboard for Danger, No Fire and PASS	Danger, Electric shock, No Fire, PASS	No	1(Each)
22	I/P and O/P wiring of Grid Connection (Red + Black) - AC cable	2.5 Sq. mm. (Tin-coated copper lugs with insulation to be used at each termination point).	Mtrs	2
23	Fire Extinguisher	Multi-Purpose - ABC Dry powder extinguishing agents (or) CO2 type with 3 kg net weight of the charge inside the cylinder.	No	1
24	Load MCB	6 A, 230 Vac (Double Pole)	Set	1
25	Combo Switch socket with box and Plate (For Grid Input)	6 A, 230 V	No	1

26	3 Pin Top (For Inverter Output)	6 A, 230 V	No	1
27	Metallic Enclosure for Solar Inverter and Battery	Metallic Enclosure for Solar Inverter and Battery – Electric shock proof, Rust resistant, small diamond grill mesh, knife proof with door and lock, Size – (L x W x H) - 3 Feet x 3 Feet x 4 Feet	No	1
28	Consumables	Includes: UPVC pipes and fittings, Flexible pipes, Screws, Nuts and Bolts, Cable lugs etc...	Set	1

Bill of Material for Load Segregation:

Sl.no	Item	Description	UoM	Qty
1	Power Cable - Red	2.5 Sq. mm, EFFR copper AC cables.	Mtrs	20
	Power Cable - Black	2.5 Sq. mm, EFFR copper AC cables.	Mtrs	20
2	16 A Combo Socket with indicators	16 A, 230 V, Socket, FR polycarbonate material (White Colour)	Nos	3
3	Earthing Cable (Green)	1 Sq. mm, EFFR copper cables. (Interconnecting earth pin (3-pin sockets) with MET)	Mtrs	25
4	Electrical Insulating Tape	Size - 18 x 0.125 mm, High insulating resistance, Moisture & Corrosion resistant, Flame-retardant, Long-lasting adhesion.	No	1
5	UPVC – Capping & Casing (White)	Polypropylene material, 25 x 10 mm, White colour, Flame retardant	Mtrs	10
6	Plastic wall plug	UPVC material, Size - 35 x 8 mm, Crack-proof, White colour, Eco-friendly.	Packs	1
7	Saddle Nail/Screw	Concrete nail Size - 1.5-inch GI/ Astel strong steel	Kg	0.25
8	Cable Tie	Polypropylene Material, Size – 150 mm, White Colour.	Packs	1
9	Cable Lugs	2.5 Sq.mm, Pin-type, Tin-coated copper.	Nos	4
10	Flexible Pipe	Polypropylene material, 20 mm diameter, White colour, Flame retardant, Anti-distortion.	Mtrs	2
11	Labelling Tags (Cables & Loads identification tags)	Size - 3 x 1 Inch, Synthetic paper, Self-adhesive, Fluorescent Green colour, Waterproof, Temperature resistant.	Pack	1

ANNEXURE 2- TECHNICAL SPECIFICATIONS OF COMPONENTS

The proposed project shall be commissioned as per the technical specifications given below. Any shortcomings or deviations may lead to the cancellation of the Letter of Award, and in such a case the Competent Authority's decision will be final and binding on the Organization.

1. SOLAR PV MODULE:

- a. The PV modules used must qualify to the latest edition of the IEC PV module qualification test.
- b. The total solar PV array capacity should not be less than the allocated capacity and should comprise TOPCON modules of minimum Wp mentioned in the bill of materials. Module capacity less than minimum Wp mentioned in the BoM / Purchase Order shall not be accepted.
- c. PV modules must be tested and approved by one of the IEC authorized test centers. The module frame shall be made of corrosion-resistant materials, preferably anodized aluminum of 10 microns thickness.

NOTE:

- Approval from SELCO Foundation should be sought before finalizing the choice of brand for SPV modules.

MODULE WARRANTY:

Module Warranty is defined as: The manufacturer should warrant the Solar Module(s) to be free from the defects and/or failures specified below for a period not less than Twelve (12) years from the date of sale to the original customer

- a. Defects and/or failures due to manufacturing.
- b. Defects and/or failures due to quality of materials
- c. Non-conformity to specifications due to faulty manufacturing and/or inspection processes. If the solar Module(s) fails to conform to this warranty, the manufacturer will repair or replace the solar module(s), at the supplier's sole cost

PERFORMANCE WARRANTY:

- The degradation of power generated by the module shall not exceed 20% of the maximum rated power over the 30-year period and not more than 8% after the first ten years period.
- Should have a positive power tolerance
- Should be Anti - L.eT.I.D & P.I.D Resistant
- Panel degradation should be linear over a period for 30 years
- Should have temperature coefficient of power (Pmax) $\leq -0.35\% / ^\circ\text{C}$
- Should be able to withstand downward force ≥ 5600 pascals
- Should be able to withstand uplift force ≥ 2400 pascals
- Should have tempered/toughened solar glass of $> = 2$ mm thickness
- Should have anti-reflective surface treatment
- Should have optically clear glass with high transmittance

Additionally, modules should be certified with:

- PV module safety standards
- PID-d.
- Ammonia corrosion Resistance test
- Dynamic Mechanical Load
- Hailstone (35mm)
- Ignitability test
- FSI Tested.
- EL Tested.
- Enlisted Module Manufacturer of DGS&D.

- Application class - Class A (Electric hazard test - Operating voltage >50 Vdc & Modules area can be accessed by public)
- Module fire performance - Type 1 (Burning test & spread of flame test)

2. MODULE MOUNTING STRUCTURE (MMS):

For very low elevation & flat RCC surface mounting:

- Landscape orientation to be incorporated.
- Triangular MMS with concrete block with wind deflectors.
- **Wind deflectors** on the East, West and North Side of each panel should be incorporated.
- Additional Ballast and anchoring should be incorporated for additional stability.
- The MMS should be mounted to the RCC roof using wedge anchor fasteners and a concrete block of L x W x H = 1.5 x 1.5 x 0.25 feet at the front side of the MMS and concrete block of L x W x H = 1.5 x 1.5 x 0.75 feet at the back side of the MMS respectively. The sides of the cube and roof interface should be given a simple 1-inch filet construction. At the top side of the cubes, an upward taper should be formed from cube sides towards M.M.S leg. M15/M20 grade P.C.C should be used for the civil works with minimum 3 days of curing.

For inclined sheet roofs/Tin roofs (General purpose mounting):

- Mini rails to be incorporated
- Anodized mini rails of 70 microns thickness.
- Mini rail dimension should be of L x H x W x T – 300mm x 100mm x 40mm x 3mm
- Mini rails can be fastened to the purlins using self-driven screws. (Pop riveting can be incorporated on PPGL sheets which are in good condition.)
- EPDM strips to be used as sealant for waterproofing.

For roofs which are unfit for mounting panels:

- Roofs that are not fit for installation due to less structural stability/very old roofs/rainwater leakage problem, then a suitable location on the ground may be preferred for the panel installation.
- The installation maybe a low elevation MMS with fencing protection around or may be a high elevation MMS (Approval and support from SELCO foundation should be taken prior to installation)

Orientation of the MMS:

- The orientation of the MMS should be due south in general case/flat mounting surfaces.
- If the roof orientation of the building is deviated away from the south (by less than 30 degrees), then the existing orientation of the building roof can be used for mounting the panels. If the deviation is more than 30 degrees, then action to correct the deviation should be taken only after consultation with SELCO Foundation.

NOTE:

- Approval from SELCO Foundation should be sought before finalizing the MMS design in case of any customization required as per the existing site situations.
- Approval from SELCO Foundation should be sought to mount the panels on an alternate location if the existing roof is unfit for mounting panels.

General guidelines:

- Each structure should have an angle of inclination as per the geographical location to receive maximum irradiation.
- All panels should be grounded together with grounding lugs and all the MMS structure should be grounded using grounding clips and should be connected to the respective earthing pit along with AJB.
- All nuts & bolts used should be made of G.I (> 120 microns) or of stainless steel.

- The structure shall be designed to allow easy replacement of any module with walking space around the MMS. The array structure shall be so designed that it will occupy minimum space without sacrificing the output from the SPV panels. Installation of solar structures should not damage the roof in any way. If any concrete or foundation is required, it should be precast type.
- Organizations must follow the above types of roof mounting options, and the solution is dependent on the type of roof at the location. a) Flat roof, b) Tin roof. In all cases, considerations must be made for the roof's age, structural integrity, access to equipment, and necessary setbacks for fire and life safety requirements.

3. ARRAY JUNCTION BOX/COMBINER BOXES:

- The junction box should have good resistances against mechanical stresses and external impacts.
- The junction boxes are to be provided in the PV array for termination of connecting cables.
- The Junction Boxes (JBs) shall be made of GRP/FRP/Powder Coated Aluminium /cast aluminium alloy with full dust, water & vermin proof arrangement.
- All wires/cables must be terminated through cable lugs. The boxes shall be such that input & output termination can be made through suitable cable glands.
- Proper cable lugs (Fork, pin type) with insulation should be provided for the cables connected with the boxes.
- A.J.B should have segregated inputs for both positive and negative cables emerging from the respective arrays.
- Positive strings should have a self-blown in-line DC fuses
- All the glands provided under the junction box should be used and any unused glands should be sealed for ingress protection.
- Suitable markings shall be provided on the busbar for easy identification and the cable ferrules must be fitted at the cable termination points for identification.
- The AJB should be placed in a shaded place, preferably at the inner side of the wall nearest to the roof.
- IP rating: IP-67.
- Should comply with the R.o.H.S. Directive 2002/95/EC

4. Battery:

The battery chosen for the project should have the following characteristics:

- **Battery type:** Valve Regulated Lead Acid (VRLA)
- **Plate technology:** Flat plate, Tubular
- **Terminal type:** L - Type
- **Operating temperature:** -20°C to +55°C
- **Application** - Cyclic application, Float application above 1 hour discharge rate
- **Self-discharge @ STC** - Low self-discharge < 3.0 % per month
- **Life cycle @ 80% D.O.D @ 27°C** – 1200 - 1500 cycles
- **Ah Efficiency:** >90 %
- **Wh Efficiency:** >80 %

Should have **additional characteristics of:**

- Should exhibit PSOC behavior
- Should have low fumes generation
- Should perform easy recovery after idle period.
- All the batteries capacities mentioned are at a C/10 rate of discharge and the same should also be followed by the Organization. The preferred voltage of each battery is 12 V due to better space utilization. However,

Organizations quoting for battery banks with 2V cells or other capacities should add a justification note as annexure to why the particular voltage was opted for. The technical committee will consider this and take a decision on the suitability of such an option. The decision of the technical committee/technical member of the buyer on this matter will be final and binding on the Organization.

- Battery should conform to the latest B.I.S/ International standards. A copy of the relevant test certificate for the battery should be furnished.
- The battery should be warranted for a minimum of 5 years.
- The battery should be installed inside the premises of the end user on a battery rack. The rack material size should be able to easily bear the battery load. (Each leg should have a respective base plate.)
- The rack's row length should be considered based on the size of the battery as well as the number of batteries placed per row including the 1-inch inter battery gap.
- In case of double row racks, the inter row height should be of a minimum 7-inch separation.
- The battery rack should be of fireproof material and corrosion free (GI rack of 120 microns).
- In the battery rack, each joints should be with nut and bolt assembly and should not be with any type of welding assembly.
- Electrical Insulation mats (IS 15652:2006 standard) with minimum 0.4 kV insulation capacity should be provided on the floor.
- Tin-coated copper lugs (Ring type) with insulation to be used at cable ends to connect each battery terminal.
- Spring washers to be incorporated in the nut-bolt assembly at each battery terminal.
- Battery terminal caps used, should be big enough to cover the entire terminal area and the nut bolt assembly.
- At each battery terminal, petroleum-based gel coating should be applied.
- All cables connecting to the batteries should be provided "conduit pipe" protection and tied to the outer sides of the battery body using cable ties.

NOTE:

Placement of battery should be in proper ventilated room and if not then ventilation in the room should be compulsorily incorporated for the following reasons:

- Safety of the system
- Safety of the end users
- Efficient performance of the system.

Also, approval from SELCO Foundation should be sought before finalizing the choice of brand for solar batteries.

5. Grid Input Protection Box with Line Indicators:

The GIP box should have good resistances against mechanical stresses and external impacts. The Box shall be made of GRP/FRP/Powder Coated Aluminium /cast aluminium alloy with full dust, water & vermin proof arrangement.

- GIPB should have Line Indicators
- All wires/cables must be terminated through cable lugs.
- The boxes shall be such that input & output termination can be made through suitable cable glands.
- All the cables (Incoming & Outgoing) should be kept separated and should be given UPVC conduit pipe protection
- All the glands provided under the box should be used and any unused glands should be sealed for ingress protection.

- Preferably, the box should be placed in the PCU room.
- IP rating: IP-67.
- Proper cable lugs (Pin type) with insulation should be provided for the cables connected with the boxes.
- Should comply with the R.oH.S. Directive 2002/95/EC

6. Solar PCU:

The power conditioning unit should be provided to convert DC power produced by SPV modules into AC power. The power conditioning unit/inverter should be off-Grid with Grid interactive and grid charging features.

Typical technical features of the PCU shall be as follows:

Power conditioning unit with inbuilt charge controller of capacity & ratings as specified in the below for various capacities of Solar Power Plants should convert DC power into AC power.

The PCU should be tested from the MNRE approved test centres / NABL /BIS accredited testing- calibration laboratories. In the case of imported power conditioning units, these should be approved by international test houses.

In case of inverters with low ground clearance, a minimum of 3-inch elevation for the same should be incorporated. The elevating means should be a fireproof material (Leg bushes are preferable).

6.1.1 The PCU will have the following features:

- MPPT charging.
- Inverter efficiency should be more than 85%
- The inverter should be compatible with alternators / Generators.
- Output voltage for single phase 230 V, +/-3% with pure sine wave.
- Output frequency: 50 Hz
- Capacity of PCU is specified at minimum 0.8 lagging power factor
- THD: less than 3%
- Ambient temperature 50 degree Celsius (max.)
- Operating humidity 95% maximum
- Shall be equipped with RS 485 data port output

6.1.2 Protections:

- Over voltage (automatic shutdown)
- Under voltage (automatic shutdown)
- Overload - Short circuit (circuit breaker & electronics protection against sustained fault)
- Over Temperature
- Temperature compensation
- Battery, PV reverse polarity

6.1.3 Indicators

- Array on
- MPPT charger on
- Battery connected, charging
- Inverter ON
- Load on solar/ battery
- Grid charger on
- Load on Grid
- Grid on
- Fault

6.1.4 Display Parameters

- a. Battery Current
- b. Battery Voltage
- c. PV Panels Voltage
- d. PV Panels Current
- e. Energy Generation (kWh)
- f. Energy – Grid Export (kWh)
- g. Grid Voltage
- h. PCU Load (kW)
- i. PCU Output Voltage
- j. PCU Output Frequency
- k. PCU Output Current
- l. Fault Codes

6.1.5 Cooling: cooling mechanism required - Air Cooled

6.1.6 Inverter should have the RS 485 communication port and the following are the details to be provided:

- Protocol documentation of the inverter model (with clarity of firmware version and models supported).
- Mod bus registers mapping document or string data of the inverter model.

NOTE:

Placement of PCU should be in proper ventilated room and if not then ventilation in the room should be compulsorily incorporated for the following reasons:

- Safety of the system
- Safety of the end users
- Efficient performance of the system.

Also, approval from SELCO Foundation should be sought before finalizing the choice of brand for solar PCU.

6.A Solar Charge Controller:

The charge controller unit should be provided to convert DC power produced by SPV modules, into regulated DC power.

Typical technical features of the CCU shall be as follows:

Charge Controller of capacity & ratings as specified below should convert DC power into regulated DC power.

The CCU should be tested from the MNRE approved test centres / NABL /BIS accredited testing calibration laboratories. In the case of imported charge controller units, these should be approved by international test houses.

The CCU will have the following features:

- a. PWM charging.
- b. CCU Efficiency should be more than 95%
- c. Ambient temperature 50 degree Celsius (max.)
- d. Operating humidity 95% maximum
- e. Optional with RS 485 data port output
- f. Wall Mounted

Protections:

- a. PV Over voltage
- b. PV under voltage
- c. Battery Low Disconnect (automatic shutdown)

- d. Battery Reconnect (automatic Turnon)
- e. Battery Over Voltage (automatic charger shutdown)
- f. Overload - Short circuit (electronics protection against sustained fault)
- g. Over Temperature
- h. Temperature compensation
- i. Battery, PV reverse polarity

Indicators

- a. Array on
- b. Charger on
- c. Battery connected, charging
- d. Fault

Cooling: cooling mechanism required - Passive / Active

NOTE: Placement of CCU should be wall mounted with base plate and in proper ventilated room and if not then ventilation in the room should be compulsorily incorporated for the following reasons:

- Safety of the system
- Safety of the end users
- Efficient performance of the system.

Also, approval from SELCO Foundation should be sought before finalizing the choice of brand for solar CCU.

7. Protections:

The system should be provided with all necessary protections like earthing and lightning protection :-

1. LIGHTNING PROTECTION: Code of practice for protective measures against lightning strikes and surges as per IS 2309-1989 and subsequent amendments should be followed. The main aim in this protection shall be to reduce the over voltage to a tolerable value before it reaches the PV or other sub system components. The source of over voltage can be lightning, atmosphere disturbances etc. The entire space occupying the SPV array shall be suitably protected against lightning by deploying the required number of lightning arresters.

- Franklin Rods/Passive type lightning arresters should be incorporated.
- The entire lightning arrester set up (Air terminal pole, spikes and base plates should be of **(solid Aluminium Alloy)**).
- Minimum size of the lightning arrester should be 15 mm by diameter and 2000 mm by length.
- The base plate should be 90 mm X 90 mm X 5 mm in dimension
- **RCC roof** - GI Elevation pole 40 mm diameter and 3000 mm height.
- **Inclined Sheet roof** - GI Elevation pole 40 mm diameter and 1500 mm height.
- The lightning protection system incorporated in the installation is only for the protection of the solar PV systems installed.
- The lightning arrester setup should always be vertical and should be stable against high wind loads.
- Insulation should be provided between the lightning arrester and the building structure.
- The lightning arrester should be placed preferably at the back of the array and at the sides.
- **From Lightning arrester to ground level:** Copper Earthing (Green) cable of 16 sq.mm should be used. (Tin-coated copper lugs with insulation to be used at the cable-earth electrode interface)

NOTE:

Copper bonded and G.I rods are not allowed in the installation.

Approval from SELCO Foundation should be sought before finalizing the choice of brand for lightning arresters.

2. **EARTHING:** Code of practice for protective earthing and protection against electric shocks as per the IEC 62305 and latest standards should be followed. Earthing is a way of transmitting any instant electricity discharge directly to the ground by providing a low resistance path (using electrical cables wires with no joints or metal strips with lesser joints). This instant electricity discharge is mostly in the form of lightning, surge voltages entering through grid lines and due to fault current/leakage current in the system. The goal is to protect the appliances from voltage surges and protect the users from the risk of electrocution due to leakage/fault current in the system.
- Earthing type - Chemical Earthing
 - Electrodes used should be a **Solid (Steel) copper-bonded electrode with 250 microns of bonding thickness**
 - The electrode should be minimum of 48 mm by diameter and 1000 mm by length, placing should be 500 mm from ground level.
 - Earth backfill compound - Clay based (High Moisture), Graphite based (For normal soil conditions) and Bentonite based (For rocky soil conditions) should be used.
 - Earth pit should be filled with back fill compound.
 - Earth pit should be 9-inch by diameter and 1500 mm by depth (As long as the electrode's length.)
 - Individual MET (Main Earthing Terminal) / copper Busbar 6-inch long, 5-hole, 3 mm thick for AC Loads should be provided for these components: Grid input protection box, Inverter/PCU, Changeover Switches, connected loads and Inverter rack.
 - Individual MET (Main Earthing Terminal) / copper Busbar 6-inch long, 5-hole, 3 mm thick for DC Loads should be provided for these components: Panel + MMS, A.J.B, Switch disconnecter and Battery rack.
 - Individual earthing for Lightning Arrester should be provided.
 - Interconnection of LA earthing - Each lightning arrester will have its respective down conductors going down to the respective earth pits.
 - Individual cable from each MET and LA down conductor should terminate at Earthing rod connector with tin coated copper lugs.
 - A minimum of 1.5 m distance from building foundations and sumps.
 - Earthing pits should have a chamber set at the ground level and should be closed with a metallic lid/F.R.P lid and should have access for maintenance.
 - Cable lugs of 16 Sq.mm with insulation should be used for cable-type down conductors to connect with the electrode.
 - Proper cable-to-rod & strip-to-rod clamps should be used.
 - Earth pit resistance should ideally be 0.5 Ohms and should not exceed 5 Ohms.
 - Earth pit should be given an identification/markings to the devices/structures they are connected to.
 - The earthing electrodes used in the project should have CPRI test certification.

NOTE:

G.I electrodes are not allowed in the installation.

Approval from SELCO Foundation should be sought before finalizing the choice of brand for earth electrodes.

8. CABLES (Over-ground cables):

GENERAL INDOOR/AC CABLES:

(Grid input to G.I.P.B -> Inverter -> Changeover switch -> Load distribution box) -> Changeover switch (Solar & Grid-DG input)

Stranded cable conductors should be made of high purity annealed 99.97% electrolytic grade copper with unadulterated FR PVC insulation.

Cable size as mentioned in the bill of materials to be used in the project.

The cables used shall have the following characteristics:

- High thermal stability and temperature withstanding range: -15°C to +85°C.
- Should have a temperature index of 300°C.
- Should have excellent resistance to heat, cold, water, oil, abrasion & UV radiation.
- Should have flexibility & higher bending capacity- 8D minimum bending radius (EFFR wires).
- Should have anti-rodent & anti-Termite resistant properties.
- Should have a high oxygen index (LOI) of > 30%.
- Should have high insulation resistance/Rated for nominal voltage (Uo/U): 600/1100 V.
- Should have low conductor resistance (Maximum conductor resistance at 20°C < 7.41 Ω).
- Should have low smoke density and emissivity (Corrosive halogen acid & toxic gasses below 18%).
- Should be 100% bunching & 100% conductive.
- Should be lead free.

NOTE:

The cables chosen for the project:

- should have passed the flame-resistant flammability test.
- Should confirm the sizing standards tests.
- Should be RoHS & Reach Compliant and should be NABL accredited.
- Cables of multiple brands should not be used in the installation.
- Should have the IEC, CE & ISI certification
- Cables of multiple brands should not be used in the installation

Also, approval from SELCO Foundation should be sought before finalizing the choice of brand for AC cables.

SOLAR CABLES/D.C. CABLES/OUTDOOR CABLES:

(Panels -> arrays -> A.J.B -> inverter)

Solar cables should have these specified constructional features:

Type PV1 - F (With double insulation)

- **Conductor:** Fine stranded Wire Tinned Copper Conductor according to BS EN 60228:2005 cl. 5
- **Insulation:** UV resistant, cross linkable, halogen free, flame-retardant compound for core insulation
- **Core Identification:** Red/Black
- **Sheath:** UV resistant, cross linkable, halogen free, flame-retardant compound for Sheath over insulation
- **Cable Colour:** Red/Black
- **Voltage Rating:** 0.6 / 1.0 kV

BATTERY CABLES:

(Battery -> Battery -> Inverter)

Battery cables should have these specified constructional features:

- **Cable type:** Flexible cable
- **Insulation type:** Double Insulation
- **Insulation material:** Rubber with Flame-retardant, Oil-resistant
- **Conductor:** Fine multi stranded wires, Tinned Copper Conductor
- **Cable colour:** Black
- **Core Identification:** White
- **Crimping:** Both ends crimped

- **Voltage Rating:** 0.6 / 1.0 kV

NOTE:

- Cables of multiple brands should not be used in the installation.
- Should have the IEC, CE & ISI certification

The DC cables chosen for the project should have the following tests passed:

- Flame resistant flammability test.
- The sizing standards tests
- RoHS & Reach compliant

Also, approval from SELCO Foundation should be sought before finalizing the choice of brand for DC cables.

A. - COLOR CODING & LABELING:

- Correct color codes should be followed for the laying of the cables.
- **For the DC side** - Red color for the positive side and Black color for the negative side should be incorporated and cables of other colors should not be used.
- **For the AC side/Single phase** - Both input and output (DB) of the inverter, Black color to be used for the neutral and Red color to be used for the line.
- **For the AC side/Three phase** - Both input and output (DB) of the inverter, Black color to be used for the neutral and Red, Blue & yellow color to be used for the lines.
- **For earthing** - Green-Yellow color should be used for the earth down conductors.
- **Labelling:**
- Each set of cables should be appropriately labelled by mentioning their origin point and their terminal point and should be easily identifiable for maintenance purposes.
- The components to which the cables are interconnected to, should be clearly labelled
- Labels should be made using permanent markers on white label tags

The cable should be so selected that it should be compatible up to the life of the solar PV panels i.e., twenty-five (25) operational years. Cable ends should be crimped along with cable lugs thoroughly using appropriate lugs. This cable-lug interface must be Insulated. Tin-coated copper cable lugs with respect to cable sizes should be used and they should be of required current ratings. Connectors (MC4) used for the solar cables should be of an IP-67 rating or higher.

Conduit pipe protection to be given to cables connecting:

1. Battery to battery,
2. Battery to inverter,
3. All cables entering the inverter.

DC/Solar cables from PV arrays and earthing cables should be given UPVC pipe protection. The end points of the conduit pipes should be protected from the rainwater/termites/insect's ingress by using appropriate sealant (Foam duct sealant). Cable Tie for outdoor application should be UV resistant. UPVC long "L-bend" pipes to be used wherever the cables pass through sharp edges/roof edges/angles in the wall.

AC cables entering the inverter from the grid input box, and all cables running from inverter up to the main distribution board should be provided with UPVC conduit pipe protection as well.

UPVC conduit pipes of 19 mm by diameter should be used. UPVC long-L-bends of 19 mm diameter should be used at the corners, edges. UPVC 2-way/3-way junction boxes should be used at regular spacing for maintenance purposes. The brands used here should be **ISI** certified.

NOTE:

- Cables should not be left open and should be covered through conduit pipes.
- For DC connections use only DC cables and same for AC connections use only AC cables and do not interchange or mixed.
- Ordinary PVC conduit pipes, bends and junction boxes are not allowed in the installation/to protect the DC & AC cables.

9. LOAD WIRING:**Type-1, 100% new load wiring:**

- Upon installation of the solar PV systems, the output power from the P.C.U should be fed to solar loads only.
- Laying of cables should be followed by strictly implementing the below mentioned clauses of annexure 2:
 - 10: Cables/AC cables
 - 10-A: Colour coding & labelling
 - 9.2: Earthing
 - 11: Change-over switches
- Cable & lug sizes should be as per relevant load capacity/wattage.
- Cable tools such as wire stripper, crimping tools and heat shrink sleeve kits should be used to manage the cables
- Hammer drill tool set, along with core drill-bit should be used to manage cables through the walls
- UPVC solid conduit pipe protection should be provided to protect the connections (new cables laid) made throughout the center. UPVC Junction boxes should be used at junction points for ease of installation and maintenance. Long UPVC bends should be used at sharp edges and bends in the wall.
- Labeling should be done for the components and connections as mentioned below:
 - **Label the changeover switch:**
 - Outside the door of the switch, all three positions of the lever should have sticker in BOLD LETTERS namely "**Solar - Off - Grid**"
 - The incoming solar lines, the grid/DG lines from COS-2 and the outgoing lines to new DB should be labeled

Type-2, Heavy load segregation:

- Upon installation of the solar PV systems, the output power from the P.C.U should be fed to solar loads only.
- Non-solar loads i.e., loads other than i.e., heavy loads and non-critical loads, should be separated from the solar lines and these non-critical loads should be simultaneously powered using grid power (using the separate wiring at the Anganwadi center). The provision to separate the solar loads & non-solar loads using two separate sets of wiring should be made at the Anganwadi centers on a top-priority basis.
- Laying of cables should be followed by strictly implementing the below mentioned clauses of annexure 2:
 - 10: Cables/AC cables
 - 10-A: Colour coding & labelling
 - 9.2: Earthing
 - 11: Change-over switches
- Cable & lug sizes should be as per relevant load capacity/wattage.
- Cable tools such as wire stripper, crimping tools and heat shrink sleeve kits should be used to manage the cables
- Hammer drill tool set, along with core drill-bit should be used to manage cables through the walls

- UPVC solid conduit pipe protection should be provided to protect the connections (new cables laid) made throughout the center. UPVC Junction boxes should be used at junction points for ease of installation and maintenance. Long UPVC bends should be used at sharp edges and bends in the wall.
- Labeling should be done for the components and connections as mentioned below:
 - **Label the Non-Solar Loads:**
 - The gang box of the 3-pin sockets provided should be provided with a sticker and the sticker should be 3 Sq. inch by area.
 - The sticker should have a main title "**Grid Power**" on top and a subtitle on the bottom. The name of the solar load that is to be connected with the socket should be mentioned in the subtitle (Say AC, Autoclave, Water Pump etc)
 - Stickers should be pasted such that the name of the non-solar load can be seen from the front of the socket and the other part of the sticker covers the side of the gang box.
 - **Label the changeover switch :**
 - Outside the door of the switch, all three positions of the lever should have sticker in BOLD LETTERS namely "**Solar - Off - Grid/DG**"
 - The incoming solar lines, the grid/DG lines from COS-2 and the outgoing lines to new DB should be labeled

10. CHANGE-OVER SWITCHES:

- Knife-type, metal case changeover switches should be used
- Plastic case changeover switches should not be used.
- Changeover switches as per the B.O.M specifications should be used.
- Labeling of the entry & exit points of cables should be clearly marked.
- The lever position at the changeover switch for "Solar" - "Off" - "Grid" should be clearly marked with permanent marker/labels.
- Metal case should be provided with earthing protection.

11. PLAQUES, SLD, SIGN BOARDS, BOM & LOAD DETAILS:

Foam Plaques:

- "DOs & DON'Ts" practices for panel, battery and P.C.U handling/routine maintenance tips
- should be pasted at the battery-inverter room
- The size of the plaque should be of A4 size for each component i.e panel, battery & P.C.U maintenance. All the three plaques should then be made as one unit for better geometry of appearance and application over the wall.
- The plaque should carry the contact details of the Organization incharge of the projects, with their office address and customer care contact details. It is suggested to also have alternate contact details included in it for better reach out.
- The plaque should be of the dimensions specified in the BOM
- The plaque should be placed at an average height of 5 feet above the ground at the entrance of the battery-inverter room and should be easily readable.
- Both local language and English should be incorporated in description of details in the plaque
- Strong adhesive (Double sided glue tape) along with washer-screw-wall plugs, should be used to keep the plaques firmly stuck to the wall

Metal plaques:

- The plaques should be placed at the entrance of the main building or at the reception counters making them easily noticeable for the visitors at the Center
- The plaque should be placed at a height of 6-feet from the floor and mounted firmly over the wall using self-tapping screws and plastic reinforcement

SLD of PV system:

- A single line diagram of the entire solar PV system components installed and the way they are interconnected at the center should be clearly printed along with their electrical specifications mentioned for each component.
- The size of the SLD board should be as per the BOM specifications
- The Sunboard material used to draw the SLD should be a minimum of 3-mm thick and should be glued to the wall firmly along with washer-screw-wall plugs, should be used to keep the plaques firmly stuck to the wall
- The SLD board should be placed in the same room as that of the battery-inverter set-up, and depending upon the room condition the SLD board should be placed such that it gets maximum visibility

Note:

SELCO Foundation will provide the content for SLD.

Sign boards:

- A caution sign board mentioning prohibition of smoking and open flames should be placed at the entrance of the battery-PCU room.
- High voltage & Danger symbol to be depicted at the entrance of the room
- Fire extinguisher operating procedure (PASS sequence) during emergency

Earth pits:

- Earth pit should be given a labelling to identify.
- The size of the sign board should be of A5 size and should be supported by a GI pole of 2.5 feet tall (1.5 feet above the ground), of 2 mm thickness and of 120-micron galvanizing thickness.
- The sign board should have the details

12. FIRE EXTINGUISHERS:

The chosen fire extinguishers should be of the ABC Dry powder extinguishing agents or CO2 type with a minimum of 3 Kgs of charge or more in the cylinder. The fire extinguishers should be PESO/CCOE approved and CE certified.

Fire extinguishers should have the features as follows:

- Average discharge (%): >95%
- Average discharge time: >9 sec
- Average range of throw: >2 meters
- Operating temperature: -30°C to +60°C
- Fire rating: >1A:34B

Fire extinguishers should have the characteristics as follows:

- Non conductive
- Maximum visibility during discharge
- No thermal (or) static shocks

NOTE:

The fire extinguisher should be placed at the entrance of the battery room and should be serviced periodically to ensure there is proper charge and pressure in the cylinder.

13. SYSTEM COMPLETION-HANDOVER REPORTS:

- Once the installation is complete, the system functionality should be verified, and the instantaneous electrical parameters should be recorded and should be mentioned in the report and the same should be submitted to the SELCO foundation.
- The format sequence to record the parameters should be collected from SELCO foundation.
- All the components used in the installation process, their specifications, the quantity used, grand total should be clearly specified.
- Close-up pictures of the main components of solar PV set-up with GPS coordinates clicked at respective sites should be submitted along with the completion report and should be in the order as follows:
- Solar PV arrays
- A.J.B
- Battery bank
- P.C.U set-up
- G.I.P.B
- Combiner box
- Earth pits
- Lightning arrester
- Change-over switches
- Cable management (outdoor & indoor)
- Foam plaques
- Metal plaques
- SLD
- Load details pasted
- Earth pit sign boards

14. TOOLS & TACKLES AND SPARES:

After completion of installation & commissioning of the power plant, necessary tools & tackles shall be maintained by the successful Organization for maintenance purposes at the local service center.

15. SAFETY MEASURES:

The Organization shall take entire responsibility for electrical safety of the installation(s) and follow all the safety rules & regulations applicable as per Electricity Act, 2003 and CEA guidelines etc.

The work is to be done in a Anganwadi Centre that will be in service. During installation, care shall be taken to ensure no hindrance is caused to patients and medical professionals in the building while they will be on their work.

16. OPERATION AND MAINTENANCE MANUAL:

An operation, instruction and maintenance manual in English and/or local language should be provided along with the solar system. The following minimum details must be provided in the manual:

- Basic principles of photovoltaics.
- A block diagram on Solar PV System - Showing interconnection of its components viz PV modules, batteries, inverters & Charge controls and loads.
- A small write up on expected performance of the SPV systems.

- A list of the critical loads (luminaries and medical equipment) that are to be connected to the solar PV system.
- A separate list of heavy loads which are never to be connected to the system.
- A list containing specification details of panels, batteries, P.C.U., showing type of the model used, model number, voltage & current capacity
- A list of total numbers of items (Solar panels, battery, inverter, earthing pits, lightning arresters, luminaries, fans and medical equipment) that are provided to the center.
- Significance of audio and visual indicators of the solar PV system.
- A SLD of the system installed.
- Clear instructions on regular maintenance and troubleshooting of the solar PV System.
- A list of DOs and DON'Ts practices while handling the solar PV system.
- Name, address and contact details of the customer care service/service provider for repair complaints and scheduled & unscheduled maintenance services.

17. ANNUAL MAINTENANCE:

- Two Scheduled visits per year with 6 months of interval gap should be done.
- Schedule visits should consist of basic maintenance of the system:
 - Cleaning of panels and inspecting their condition and performance
 - Cleaning of batteries & inspect the battery performance.
 - Inspecting inverter performance.
 - Verifying the battery-inverter room has proper ventilation maintained.
 - Verifying the DOs & DON'TS plaques, SLD & load details sheets are present in the battery room.
 - Verifying the connectivity & condition of earth pits, ensure the resistance of the earth pits is below 5 Ohms.
- Inspecting complete wiring (solar PV system with loads connected) as per bill of material.
- Verifying that non-solar loads are not connected to solar system.
- Ensure all the solar loads (luminaries, fans, medical equipment) are functional.
- Verifying all the control switches & regulators of solar loads are functional.
- Ensuring the lightning arrester set-up is intact.
- Checking and verifying system performance with prescribed format provided by SELCO Foundation.

ANNEXURE 3: COUNT OF ANGANWADI CENTRES

Indicative count of Anganwadi Centres is as follows. However, the sites are subject to change further to the site survey. SELCO Foundation will have the complete right on the selection of Anganwadi Centres across Karnataka state.

Sr No	Quote for Option	Count of Systems
1	Anganwadi Option 1: DC System	1500
2	Anganwadi Option 2: With Full load wiring	160
3	Anganwadi Option 3: With Full load Segregation	240

S.No	District	Cluster	System Capacity	System Type	No. of Centers
1	Bidar	Cluster 1 – North Karnataka A	Anganwadi Option 1: DC System	DC	100
2	Kalaburagi (Gulbarga)	Cluster 1 – North Karnataka A	Anganwadi Option 1: DC System	DC	188
3	Yadgir	Cluster 1 – North Karnataka A	Anganwadi Option 1: DC System	DC	187
4	Belagavi	Cluster 1 – North Karnataka A	Anganwadi Option 1: DC System	DC	187
Cluster 1 Sub-total					662
5	Raichur	Cluster 2 – North Karnataka B	Anganwadi Option 1: DC System	DC	188
6	Koppal	Cluster 2 – North Karnataka B	Anganwadi Option 1: DC System	DC	188
7	Ballari (Bellary)	Cluster 2 – North Karnataka B	Anganwadi Option 1: DC System	DC	187
8	Vijayanagara	Cluster 2 – North Karnataka B	Anganwadi Option 1: DC System	DC	187
Cluster 2 Sub-total					750
9	Doddaballapura	Cluster 3 – Central / South Karnataka		AC	300
10	Shivamogga	Cluster 3 – Central / South Karnataka		AC	100
11	Chamarajanagar	Cluster 3 – Central / South Karnataka	Anganwadi Option 1: DC System	DC	88
Cluster 3 Sub-total					488

ANNEXURE 4: SELECTION OF COMPONENT

SOLAR FOR OPTION 1- DC System:

Component	Specifications	As per BoM	Responses
Solar Module	Make/manufacturer		
	Type	Monoperc - Half cut cells	
	Product Warranty	> 10 Years	
	Performance Warranty	>= 25 Years	
	Power tolerance		
	Number of cells		
	Power in Wp	125	
	Voc(V)		
	Isc (I)		
	Vmp(V)		
	Imp(I)		
	Module Efficiency		
	Each Panel Capacity (Wp)	125	
	Total Panel Quantity (Nos)	2	
	Total Panel Capacity (Wp)	250	
	No of Panels connected in series	1	
	No of Parallel Strings	2	
	Solar Battery - Flooded Lead Acid	Make/Manufacturer	
C rating		C10	
Type / Chemistry		Valve Regulated Lead Acid (VRLA)	
Plate technology		Tubular/ Flat	
Product Warranty - Replacement		5 Years / 60 Months	
Battery Voltage		12 V	
Each Battery Capacity (Ah)		100	
Total Battery Quantity (Nos)		1	
Design capacity of battery in terms of kWh		1.2	
No of batteries connected in series		1	
No of Parallel Strings		1	
No of cycles @80% DOD			
Self-Discharge rate			
Wh efficiency		>= 80%	
Ah efficiency		>= 90%	
Solar Charge Controller (CCU)	Make/manufacturer		
	Product Warranty	5 Years	
	Mounting Type	Wall Mounted	
	Type of charge controller		
	CCU Capacity	20 A, 12 Vdc	
	Efficiency of charge controller	> 95%	

	Maximum input voltage range (Voc)		
	Data Port Output	RS 485	
	Over voltage protection	Yes	
	Under voltage protection	Yes	
	Battery Low Disconnect (Automatic Shutdown)	Yes	
	Battery Reconnect (Automatic Turnon)	Yes	
	Battery Over Voltage (Automatic Charger Shutdown)	Yes	
	Overload protection	Yes	
	Over Temperature protection	Yes	
	Temperature Compensation	Yes	
	Battery reverse polarity protection	Yes	
	Panel reverse polarity protection	Yes	
DC Cables - Solar - PV1-F	Make		
	Type		
	Conductor Material	Copper	
	Insulation Material		
	Voltage Rating	1500	
	Operating Temperature range		
DC Cables - Battery	Make		
	Type		
	Conductor Material	Copper	
	Insulation Material	PVC insulated	
	Voltage Rating	1500	
	Operating Temperature range		
Load Side MCB	Double Pole MCB Make		
	Double Pole MCB Rating	20 A, 250 Vdc	
Fire Extinguisher	Make		
	Extinguishing Medium	ABC Dry powder	
	Net Weight of Charge	2 kg	
	Total Capacity		
Switch Disconnect			
Battery - DC	Make		
	Type	Double Pole	
	Rating	25 A, 250 Vdc	
PV - DC	Make		
	Type	Double Pole	
	Rating	20 A, 250 Vdc	

SOLAR FOR OPTION 2&3: AC System

Component	Specifications	As per BoM	Responses
Solar Module	Make/manufacturer		
	Type	TOPCON (N Type)	
	Product Warranty	>= 12 Years	
	Performance Warranty	>= 30 Years	
	Power tolerance		
	Number of cells		
	Power in Wp		
	Voc(V)		
	Isc (I)		
	Vmp(V)		
	Imp(I)		
	Module Efficiency	> 20%	
	Each Panel Capacity (Wp)	630	
	Total Panel Quantity (Nos)	1	
	Total Panel Capacity (Wp)	630	
	No of Panels connected in series		
	No of Parallel Strings		
Solar Battery	Make/Manufacturer		
	C rating	C10	
	Type / Chemistry	VRLA	
	Plate technology	Tubular/ Flat	
	Product Warranty - Replacement	5 Years / 60 Months	
	Battery Voltage	12 V	
	Each Battery Capacity (Ah)	150	
	Total Battery Quantity (Nos)	1	
	Design capacity of battery in terms of KWh	1.8	
	No of batteries connected in series		
	No of Parallel Strings		
	No of cycles @80% DOD		
	Self-Discharge rate		
	Wh efficiency	>= 80%	
Ah efficiency	>= 90%		
PCU	Make/manufacturer		
	Product Warranty	5 Years	
	Total Harmonic Distortion (THD)		
	Inverter Capacity (kVA)	1	
	System Voltage (Battery Input voltage)	12 V	
	Output voltage	230	
	Output frequency	50 Hz	

	Compatible with Alternators / Generators		
	Type of charge controller (DC-DC converter)	MPPT	
	MOSFET / IGBT Based		
	Efficiency of charge controller(DC-DC converter)	> 90%	
	Maximum input voltage range(Voc)		
	Input MPPT range (Vmpp)		
	Inverter minimum response time	< 20 mS	
	RMS data type	RS 485	
	No Load Power when Inverter is ON condition		
	Power Factor	0.8	
	Inverter Efficency	> 85%	
	Cooling Mechanism (Active / Forced)		
	Operating humidity		
	Over voltage protection	Yes	
	Under voltage protection	Yes	
	Overload protection	Yes	
	Over Temperature protection	Yes	
	Battery reverse polarity protection	Yes	
	Panel reverse polarity protection	Yes	
Changeover Switch	Make		
	Type	Knife	
	Rating	16 A, 230 Vac	
DC Cables - Solar - PV1-F	Make		
	Type		
	Conductor Material	Copper	
	Insulation Material	PVC Insulated	
	Voltage Rating	1500	
	Operating Temperature range		
DC Cables - (AJB - Inverter) & Battery	Make		
	Type		
	Conductor Material	Copper	
	Insulation Material	PVC Insulated	
	Voltage Rating	1500	
	Operating Temperature range		
AC Cables	Make		
	Type		
	Conductor Material	Copper	
	Insulation Material	PVC Insulated	
	Voltage Rating	1000	
	Operating Temperature range		
Cables - Earthing	Make		

	Type		
	Conductor Material	Copper	
	Insulation Material	PVC insulated	
	Voltage Rating		
	Operating Temperature range		
Earthing Electrode	Make		
	Type	Copper Bonded Electrode	
	Bonding Thickness	250 microns	
	Diameter	48 mm	
	Length	1000 mm	
	Backfill compound (Clay / Graphite / Bentonite)		
	Backfill Compound Qty	25 Kg	
Lightning Arrestor	Make		
	Type	Solid Aluminium Alloy	
	Diameter	15 mm	
	Length	2000 mm	
Grid Input Protection Box	Double Pole MCB Make		
	Double Pole MCB Rating	16 A, 230 Vac	
	Double Pole SPD Make		
	Double Pole SPD Rating with Indicators	275 Vac, Type 2, 40 kA	
Array Junction Box	String Configuration	1 In 1 Out	
	Double Pole MCB Make		
	Double Pole MCB Rating	25 A, 500 Vdc	
	Double Pole SPD Make		
	Double Pole SPD Rating with Indicators	Uc -65 Vdc, Type 2, 40 KA	
Load Side MCB	Double Pole MCB Make		
	Double Pole MCB Rating	6 A, 230 Vac	
Fire Extinguisher	Make		
	Extinguishing Medium	ABC Dry powder	
	Net Weight of Charge	3 kg	
	Total Capacity		

Load Wiring

Component	Specifications	As per BoM	Responses
Socket(Modular)	Make		
	Rating	2 Pin, 6 A	
Socket(Modular)	Make		
	Rating	3 Pin, 6 A	
Switch	Make		
	Rating	6 A, 1 Way Switch	
	Make		

Combo Socket with indicators	Rating	16 A	
Mobile Charging USB Port	Make		
	Rating	Input - 12 Vdc	
Power Cable - 1.5 Sq.mm (Red + Black)	Make		
Power Cable - 2.5 Sq.mm (Red + Black)	Make		
Earthing Cable - 1 Sq.mm	Make		
Ceiling Rose	Make		
Angle Holder	Make		
Modular Switch Box	Make		
UPVC Conduit Pipe	Make		
UPVC Capping & Casing	Make		
UPVC Fittings	Make		
Junction Box	Make		
Cable Lugs	Make		

Luminaries for AC System

Component	Specifications	As per BoM	Responses
LED Tubelight	Make		
	Rating	20 W, 230 Vac	
LED Bulb	Make		
	Rating	9 W, 230 Vac	
Wall Mounted Fan	Make		
	Rating	55 W, 230 Vac	

Note *: Luminaries for DC System

Installation of Luminaires-DC (for Anganwadi Option 1: DC System) supplied by SELCO or any third party (as communicated by SELCO) shall be the sole responsibility of the Organisation. Installation charges shall be quoted separately, included in the financial bid. This provision shall be binding upon award of the contract

ANNEXURE 5 - DETAILS OF THE ORGANIZATION

(Enclose separate sheets as necessary and in this checklist indicate yes or no)

1	Name and address of the Organization (With pin code)	
2	Year of starting the organization	
3	Registration number (photocopy of registration certificate or any other relevant document to be enclosed)	
4	Name and Contact number of the Proprietor or Point of Contact	
5	Status of Supplier- Proprietorship / Partnership/ Pvt Ltd / Limited/others	
6	GSTIN (Copies of certificates to be enclosed)	
7	PAN No. from Income Tax Dept. (Copies of certificates to be enclosed)	
8	For Single Cluster: Documents to prove last financial year business of Rs 2 Crores For overall project: Documents to prove last financial year business of Rs 6 Crores	
9	Experience of Supplier/supplier relating to supply of solar energy-based solutions (supporting certificates to be enclosed)	
10	Particulars of Physical Infrastructure and total strength of staff available in the organization.	
11	Organizations Bank details	
12	Evidence of existence (GST Registration) of local office in in the State of KARNATAKA.	

Signature of the organization and address with seal

Date:

ANNEXURE 6 – CONFIRMATION ON ENCLOSURES

Sl.No.	Description	Whether the Document is enclosed or not	Page No. From and to
1	Details of Organization as per Annexure 5	YES/NO	
2	Copies showing the legal status, places of registration and principal place of business of the firm	YES/NO	
3	Copies of audited financial statements for the last 2 years	YES/NO	
4	Copy of GST registration		
5	Copies of GST returns filed in the last 2 financial years	YES/NO	
6	Copies of income tax returns filed in the last 2 financial years	YES/NO	
7	Copy of PAN Card should be submitted	YES/NO	
8	Acceptance to provide service & Maintenance for 5 years	YES/NO	
9	Evidence of existence (GST Registration) of local offices in the state of KARNATAKA	YES/NO	
10	Letter of declaration to confirm that the organization has not been black listed by any entity or institution	YES/NO	
11	<p>For Single Cluster: Documents to prove business of Rs. 2 Crores in the last financial year</p> <p>For overall project: Documents to prove business of Rs. 6 Crores in the last financial year</p>	YES/NO	
12	Project Report on 3 successful Solar Off-grid Projects in KARNATAKA state with contact details of customer	YES/NO	
13	Implementation plan to complete Installation by 30 th November' 2026, this should include Team Structure & Team Size (no's) and installation schedule.	YES/NO	
14	Organizations bank details	YES/NO	
15	Service Level /Escalation Matrix	YES/NO	
16	Signed, sealed copies of Annexure 1, 2, 3, 4, 5 and 6	YES/NO	
17	Self-Declaration as per Annexure 4 for the components that will be used for the project	YES/NO	
18	Data Sheets/Brochures of PV Module, Battery & Inverters/PCU	YES/NO	

I abide by all the above terms & conditions.

SIGNATURE OF THE ORGANIZATION AND WITH OFFICE SEAL
DATE & PLACE:

ANNEXURE 7- SCHEDULE OF INSTALLATION

Regarding Supply, installation and commissioning

Sl. No.	Scheduled activity	Within days (no. of days)	Accepted Schedule by date
1.	Post Bidding Site Assessment	20 days	
2.	Supply starts	30 days	
3.	Completion of Installation and Commissioning of all the system	150 days	

I abide by all the commitments accepted & conditions.

SIGNATURE OF THE ORGANIZATION and with office seal

PLACE:

DATE:

ANNEXURE 8 - PRICE SCHEDULE

PARTICULARS TO BE SUBMITTED IN THE FINANCIAL BID (SECOND COVER).

PRICE SCHEDULE FOR THE SUPPLY, INSTALLATION AND COMMISSIONING & COMPREHENSIVE MAINTENANCE OF SOLAR PHOTOVOLTAIC (SPV) OFF-GRID SYSTEMS FOR 1 YEAR – FOR 1900 ANGANWADI CENTRES ACROSS THE STATE OF KARNATAKA DURING THE YEAR 2026-2027.

Rates quoted by the organization:

- a. Organizations can submit their quotes for a single cluster or overall projects as per feasibility
- b. The rates should be mentioned item wise clearly in figures
- c. Rates should be inclusive of GST however specified in the below given cell.
- d. Rates should be inclusive of AMC for 1 year.
- e. Data Sheets/Brochures of PV Module, Battery & Inverters and charge controllers have to be submitted.
- f. Rates should include transportation, installation cost for supply of solution and any other cost in the region of operation of the Organizations.

Note*:

Installation of Luminaires-DC (for Anganwadi Option 1: DC System) supplied by SELCO or any third party (as communicated by SELCO) shall be the sole responsibility of the Organisation. Installation charges shall be quoted separately, included in the financial bid. This provision shall be binding upon award of the contract.

S.No	District	Cluster	System Capacity	System Type	No. of Centers	Total Centers
1	Bidar	Cluster 1 – North Karnataka A	Anganwadi Option 1: DC System	DC	100	662
2	Kalaburagi (Gulbarga)			DC	188	
3	Yadgir			DC	187	
4	Belagavi			DC	187	
5	Raichur	Cluster 2 – North Karnataka B	Anganwadi Option 1: DC System	DC	188	750
6	Koppal			DC	188	
7	Ballari (Bellary)			DC	187	
8	Vijayanagara			DC	187	
9	Doddaballapura	Cluster 3 – Central / South Karnataka	Anganwadi Option 2 & 3: AC System	AC	300	488
10	Shivamogga			AC	100	
11	Chamarajanagar		Anganwadi Option 1: DC System	DC	88	

PART A: PRICE SCHEDULE FOR CLUSTER 1

SI No	Quote for Option	No. of systems	SOLAR SYSTEM (INSTALLATION +TRANSPORT +AMC)			LOAD WIRING/ LOAD SEGREGATION		LUMINARIES		Total per unit cost	TOTAL
			Unit Price in Rs. /Option of solar System (Installation +transport +AMC)	GST 5% on 70% of solar system unit price (Installation +transport +AMC)	GST 18% on 30% of solar system unit price against services (Installation +transport +AMC)	Unit Price in Rs. for Load Wiring/ Load segregation	GST 18%- Load Wiring/ Load segregation	Installation cost per unit for Luminaries	GST 18%		
1	Anganwadi Option 1: DC System	662									
TOTAL A											

PART B: PRICE SCHEDULE FOR CLUSTER 2

SI No	Quote for Option	No. of systems	SOLAR SYSTEM (INSTALLATION +TRANSPORT +AMC)			LOAD WIRING/ LOAD SEGREGATION		LUMINARIES		Total per unit cost	TOTAL
			Unit Price in Rs. /Option of solar System (Installation +transport +AMC)	GST 5% on 70% of solar system unit price (Installation +transport +AMC)	GST 18% on 30% of solar system unit price against services (Installation +transport +AMC)	Unit Price in Rs. for Load Wiring/ Load segregation	GST 18%- Load Wiring/ Load segregation	Installation cost per unit for Luminaries	GST 18%		
1	Anganwadi Option 1: DC System	750									
TOTAL B											

PART C: PRICE SCHEDULE FOR CLUSTER 3

SI No	Quote for Option	No. of systems	SOLAR SYSTEM (INSTALLATION +TRANSPORT +AMC)			LOAD WIRING/ LOAD SEGREGATION		LUMINARIES*		Total per unit cost	TOTAL
			Unit Price in Rs. /Option of solar System (Installation +transport +AMC)	GST 5% on 70% of solar system unit price (Installation +transport +AMC)	GST 18% on 30% of solar system unit price against services (Installation +transport +AMC)	Unit Price in Rs. for Load Wiring/ Load segregation	GST 18%- Load Wiring/ Load segregation	Unit Price in Rs. for Luminaries & Unit cost in Rs for installation of Luminaries (DC System*)	GST 18% - Luminaries		
1	Anganwadi Option 1: DC System	88									
2	Anganwadi Option 2: AC System-With Full wiring	160									
3	Anganwadi Option 3: AC System-With Load Segregation	240									
TOTAL C											

Sr no	PRICE SCHEDULE OPTION	TOTAL
1	PART A: PRICE SCHEDULE FOR CLUSTER 1	
2	PART B: PRICE SCHEDULE FOR CLUSTER 2	
3	PART C: PRICE SCHEDULE FOR CLUSTER 3	
GRAND TOTAL		

In words: Rupees _____.

ANNEXURE 9: COST VARIANCE/EXTRA MATERIAL REQUEST

SI No	Name of the Anganwadi Centre	Plant Capacity	6 Sq.mm DC solar Cable Red & black					10 Sq.mm DC solar Cable Red & black				
			QTY as per BOM	QTY as per actual/Site Assessment	Difference in QTY	Cost per meter in Rs	Price Variance In Rs	QTY as per BOM	QTY as per actual/Site Assessment	Difference in QTY	Cost per meter in Rs	Price Variance In Rs
1	Site 1	250 Wp										
2	Site 2	250 Wp										
3	Site 3	250 Wp										
4	Site 4	250 Wp										
5	Site 5	250 Wp										
6	Site 6	250 Wp										
7	Site 7	630 Wp										
8	Site 8	630 Wp										
9	Site 9	630 Wp										
10	Site 10	630 Wp										
	Sum											

ANNEXURE 10: ESCALATION MATRIX

Escalation Matrix						
SI No	Department	Name	Designation	Levels of Contact	Contact Details	Email
1				L1		
				L2		
2				L3		
				L4		
				L5		
3				L6		
				L7		

SINGLE LINE DIAGRAMS

Solar System SLD For Anganwadi Option 1

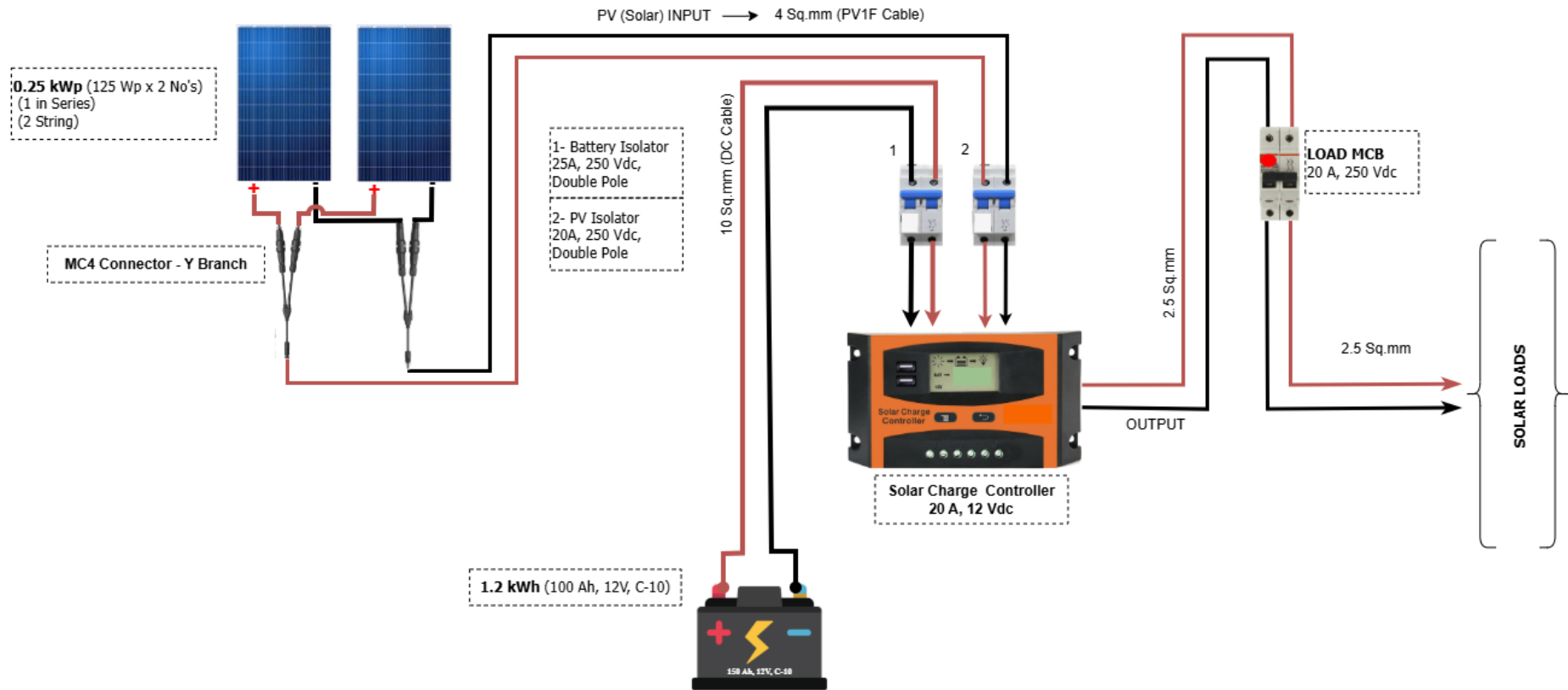

Solar System SLD For Anganwadi Option 2 & 3

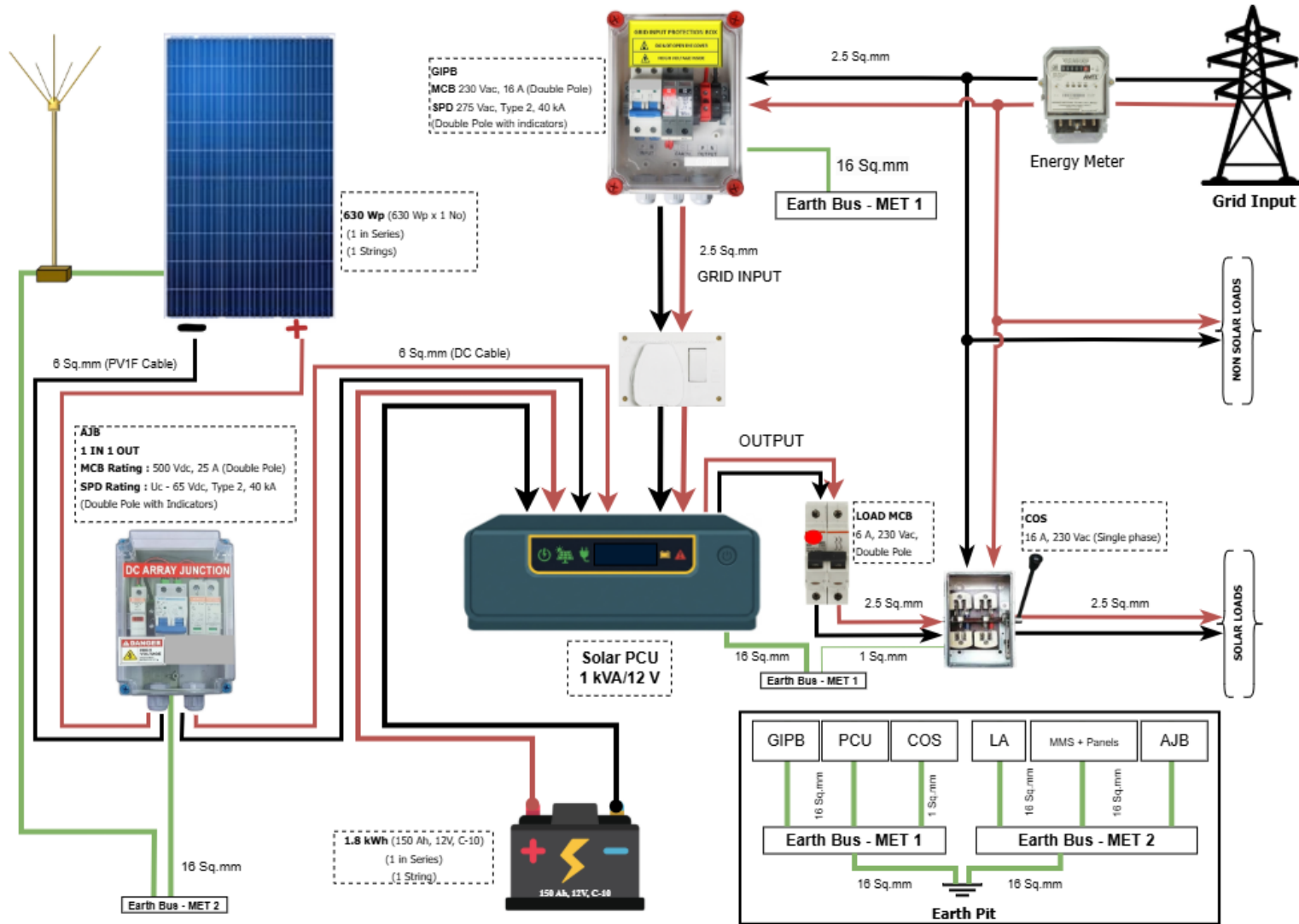

Load wiring concept

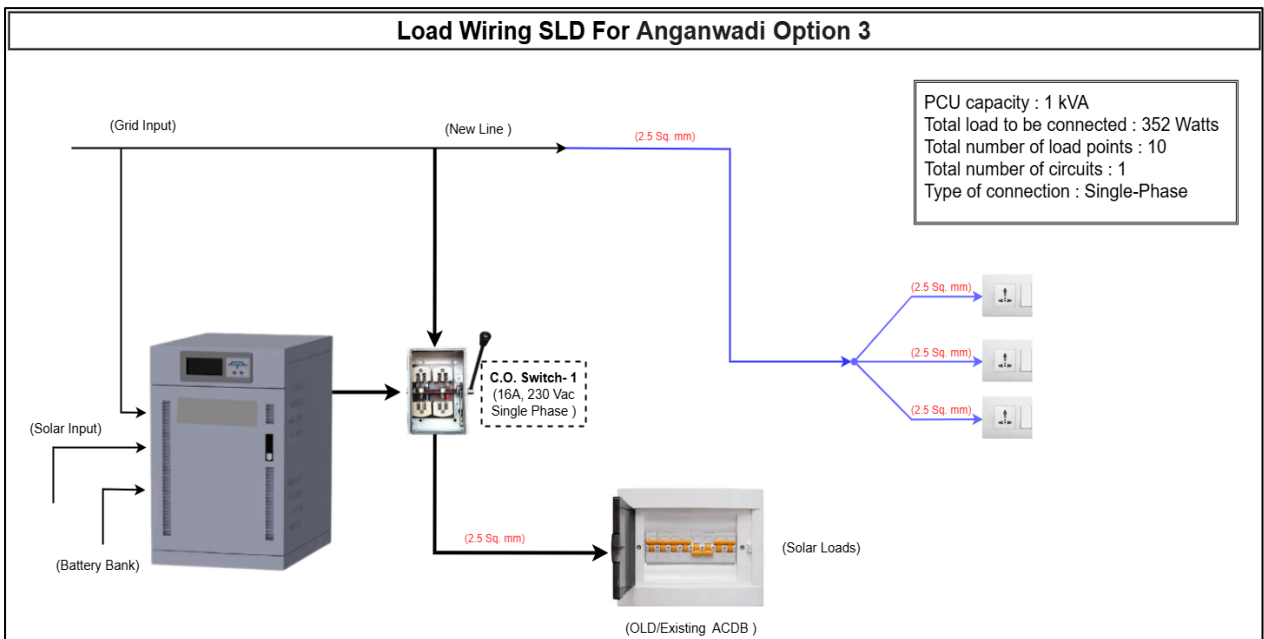
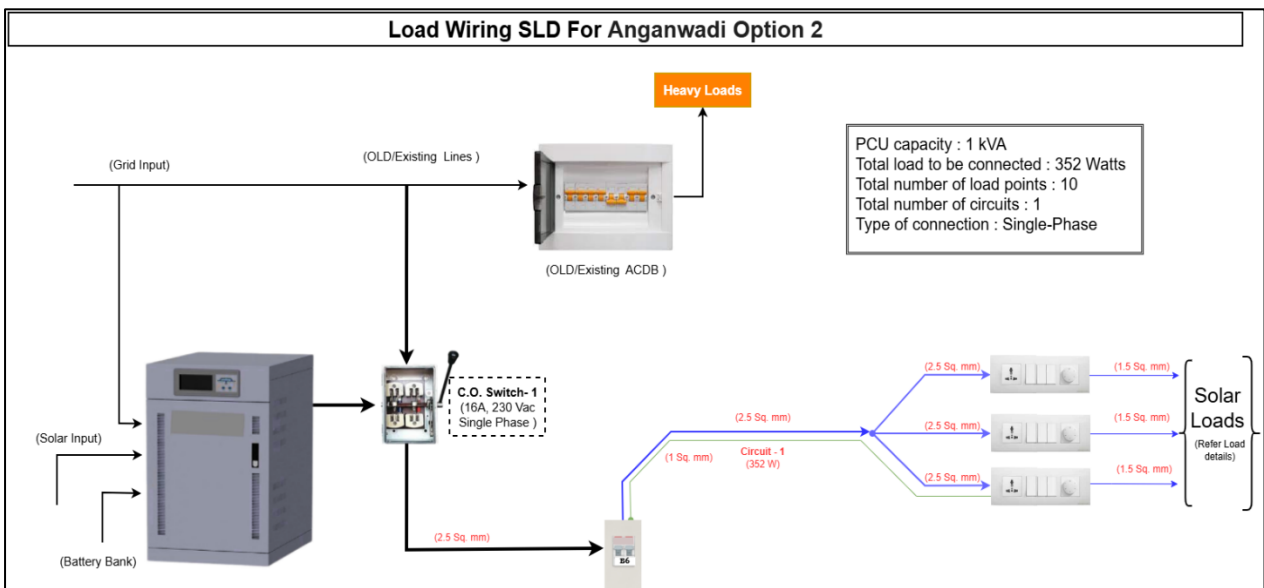
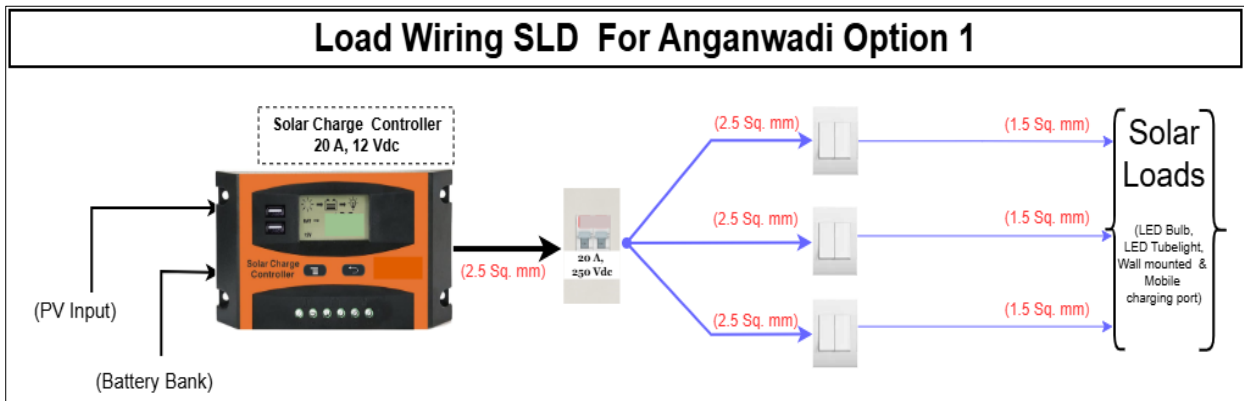

CONDITIONS:

If our tender is accepted, we hereby undertake to abide as per the stipulated Terms and Conditions to supplier and supply, installation and maintenance of solar energy-based solutions.

We agree to abide by this tender and if the work is awarded to us, in executing the above contract we will strictly observe the laws against fraud and corruption in force in India namely "Prevention of corruption act 1988".

We understand that you are not bound to determine the price based on the lowest offer that Foundation may receive.

We accept that all disputes between parties will be adjudicated by a competent court in Bangalore, India.

I, _____ (Name of signatory) on behalf of the organization _____ (Name of the organization), hereby certify that I have noted the technical specifications of solutions mentioned in Annexure 1, and the technical specifications for components mentioned in Annexure 2 and the prices quoted above are as per the details specified and in compliance with Annexure 1 and 2.

Dated this..... day of.....2026.

Signature (Name and Address of the Tender with seal) (In the capacity of.....)

Duly authorized to sign the Tender for and on behalf of _____